



BERMAD Meters

Merging monitoring & control



Sensor
MUT2200EL
Euromag Electromagnetic Flowmeter



Sensor MUT2200EL

MUT2200EL sensors represent the state of the art of Euromag International production for water cycle and process applications. The new structure for the generation of the magnetic field and the innovative route of the signal generated by the electrodes, provide a sensor with an extremely wide measurement range:

EL= Extended Linearity

This new sensors series follows the successful tradition of the MUT2200EL, introducing a measurement range of more than 1:1000 without linearization software. These kinds of performances allow very accurate measures on a wide flowrate range and to count lower flow rates that, before, would have been reset because of the effect of the converters cut off.

This flanged sensors series bases its operation on the Faraday Principle, by which a conductor crossing a magnetic field generates a potential perpendicularly orientated to the same field. In this case the flow tube made in stainless steel AISI 304 is equipped with carbon steel or stainless steel flanges, two coils are installed on the top and inferior part; the magnetic field, generated by the electric current crossing the coil, induces in the electrodes a difference in the potential proportional to the flow rate.

With the aim of measuring such potential of very low values, the interior of the flow tube is electrically insulated, thus the process liquid is no longer in contact neither with the material of the flow tube nor with that of the flange.

The converter used generates the current supplying the coil, acquires the electrodes difference of potential, process the signal to calculate the flowrate and administers the communication with the exterior. The entire sensor, when installed in the separate version, has a degree of protection IP68 suitable for a permanent immersion in water up to a depth of 1.5m thanks to a welded plate structure containing the coil and the electrodes.

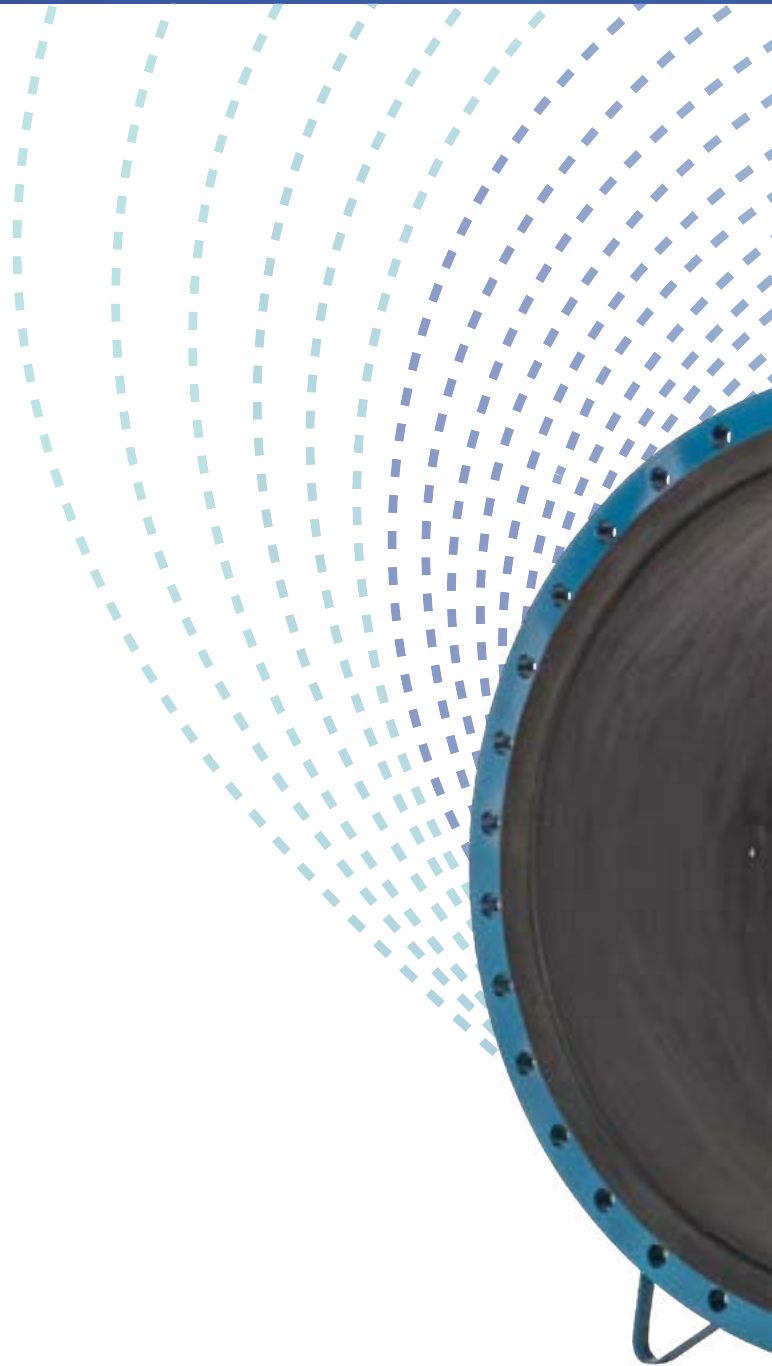

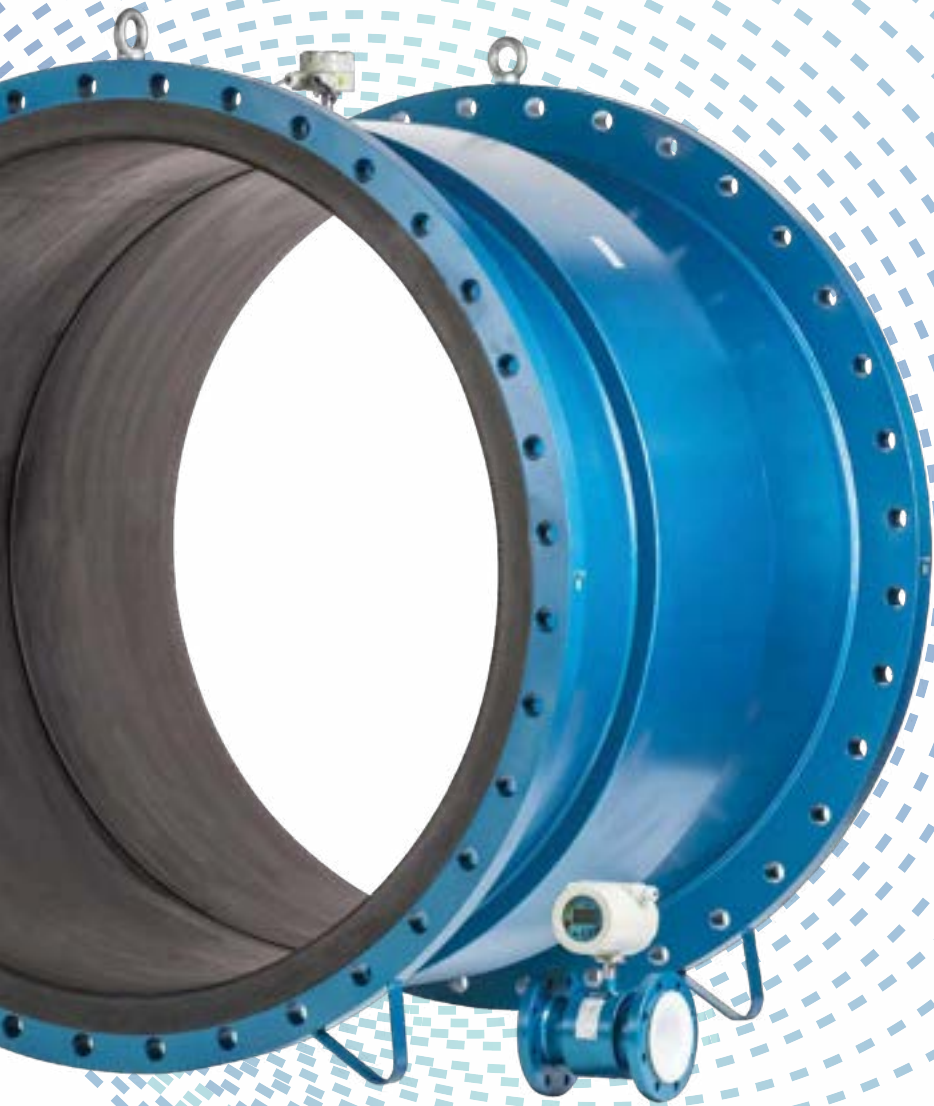

— The electromagnetic flowmeter for all applications —



DS100-6-ENG



Body and flanges

The flange and the sensor external surface are acrylic painted. This treatment gives the sensor an excellent resistance to water, even in permanent immersion. When special ambient conditions require it, the MUT2200EL may be supplied in stainless steel, flange included or special painting for C4 class environments.

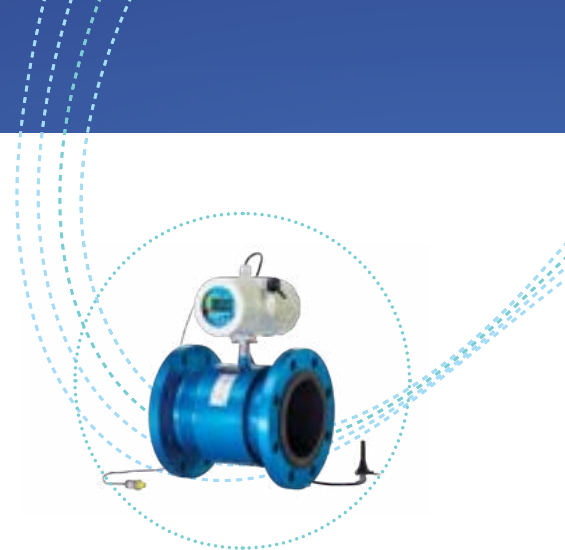

MUT2200EL - MC608A

Internal lining

The standard internal insulating lining is in PTFE for diameters from DN15 to DN100, in hard rubber (Ebonite) for diameters equal or bigger than DN125. On request, sensors may be supplied coated with PTFE with diameters bigger than DN100. The suitable temperature is limited by the type of internal lining used.



Integrated pressure sensor

Electrodes

Standard electrodes in Hastelloy C guarantee a wide compatibility with different kind of liquids; if required, they may be supplied in Hastelloy B, Titanium, Tantalum or Platinum.



MUT2200EL – MC608B – GSM – Pressure

Coupling and sensor connection

MUT2200EL sensors may be coupled with any Euromag converters. In the separate version the sensor is connected to the converter by means of cables whose length depends on the liquid conductivity; the maximum length shall not exceed 100 metres (30 meters in combination with battery operated electronics).

When installed in plastic or coated pipe lines, sensors may require the use of two grounding rings, which are inserted between the flange and the counter flange. On sensors greater or equal than DN50 an empty pipe electrode is supplied as a standard (empty pipe alarm).



MUT2200EL – PTFE liner



Reference standards

The Euromag magnetic meters are marked CE and are manufactured according to the following standards:

- 2014/35/EU - EN 61010-1:2013 (LVD) Alerts about leakages, low flow rates, high flow rates and other irregular patterns
- 2014/30/EU - EN 61326-1:2013 (EMC)
- OIML R49-1:2013
- European directive 2014/32/EU (MID)
- 2014/34/UE - IEC 60079 - 0, IEC 60079 - 18 (ATEX - IECEx) Separate version
- EN ISO 15609-1 and EN ISO 15614-1
- UNI EN ISO 12944-2, painting for C4 class environments (on request)
- PTFE conform to the norms WRAS, FDA, DPR 777/82 e DM 21/09/773
- Ebonite conform to the norms WRAS, FDA e DM174

Calibration and maximum error

MUT2200EL sensors belong to the reference Group B1 (ISO 11631). Each sensor is calibrated on an hydraulic bench equipped with a reference weighting system and SIT certified. The uncertainty of the calibration is equal to 0.2% +/- 2 mm/s. The repeatability is in the order of 0.1%.

Maximum Permissible Error is within the limits indicated in the following graph:

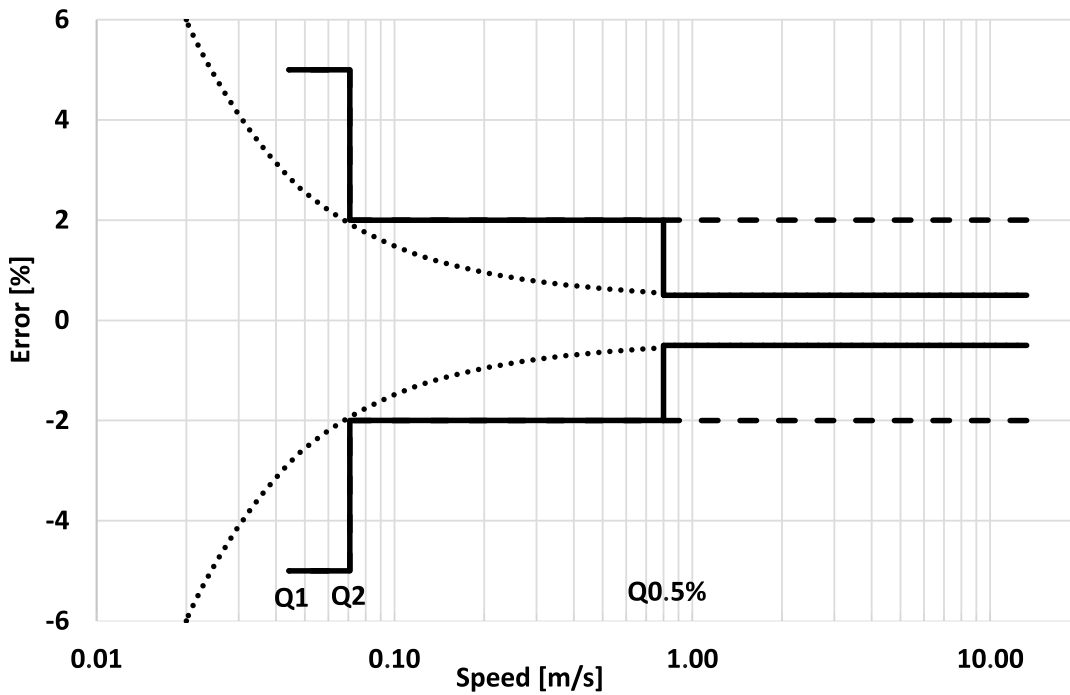

Flow rates chart

Sensor diameter	Flow rate [m ³ /h]					Ratio Q3/ Q1
	DN					
	Min. Q1	Trans. Q2	Q0.5%	Perm. Q3	Overl. Q4	
DN25 - 1"	0.080	0.128	1.40	10.00	12.50	125
DN32 - 1¼"	0.080	0.128	2.30	10.00	12.50	125
DN40 - 1½"	0.128	0.205	3.60	16.00	20.00	125
DN 50 - 2"	0.200	0.320	5.65	25.00	31.25	125
DN 65 - 2½"	0.320	0.512	9.55	40.00	50.00	125
DN 80 - 3"	0.504	0.806	14.50	63.00	78.75	125
DN 100 - 4"	0.800	1.280	22.60	100.00	125.00	125
DN 125 - 5"	1.280	2.048	35.30	160.00	200.00	125
DN 150 - 6"	2.000	3.200	51.00	250.00	312.50	125
DN 200 - 8"	3.200	5.120	90.50	400.00	500.00	125
DN 250 - 10"	5.040	8.064	140.00	630.00	787.50	125
DN 300 - 12"	8.000	12.800	200.00	1.000.00	1250.00	125
DN 350 - 14"	12.800	20.480	280.00	1.600.00	2000.00	125
DN 400 - 16"	12.800	20.480	360.00	1.600.00	2000.00	125

Sensor diameter	Flow rate [m ³ /h]					Ratio Q3/ Q1
	DN					
	Min. Q1	Trans. Q2	Q0.5%	Perm. Q3	Overl. Q4	
DN450 - 18"	25	40	460	2.500	3.125	100
DN500 - 20"	25	40	570	2.500	3.125	100
DN600 - 24"	50	80	820	4.000	5.000	80
DN700 - 28"	50	80	1.100	4.000	5.000	80
DN800 - 32"	100	160	1.450	6.300	7.875	63
DN900 - 36"	100	160	1.840	6.300	7.875	63
DN1000 - 40"	200	320	2.270	10.000	12.500	50
DN1200 - 48"	320	512	3.270	16.000	20.000	50
DN1400 - 56"	500	800	4.440	25.000	31.250	50
DN1500 - 60"	800	1.280	5.100	40.000	50.000	50
DN1600 - 64"	1.260	2.016	5.800	63.000	78.750	50
DN1800 - 72"	2.000	3.200	7.350	100.000	125.000	50
DN2000 - 80"	3.200	5.120	9.100	160.000	200.000	50



MUT2200EL general features

Flow tube material		AISI 304 (std), AISI 316																
Flanges material		Carbon steel painted (std), AISI 304, AISI 316																
Electrodes material		Electrodes material Hastelloy C (std), Hastelloy B, Titanium, Tantalio, Platinum																
Internal lining and liquid temperature		Internal lining								Liquid temperature								
		PTFE								Standard -40 /+130°C (up to +180° on request)								
		Ebonite								-40°C / +80°C								
Available Sizes		mm	15	20	25	32	40	50	65	80	100	125	150	200	250	300	350	400
		Inches	½"	¾"	1"	1¼"	1½"	2"	2½"	3"	4"	5"	6"	8"	10"	12"	14"	16"
		mm	450	500	600	700	800	900	1000	1200	1300	1400	1500	1600	1700	1800	2000	
		Inches	18"	20"	24"	28"	32"	36"	40"	48"	52"	56"	60"	64"	68"	72"	80"	
Flange standards available		EN1092-1, ANSI 150, ANSI 300, ANSI 600, ANSI 900, DIN 2501, BS 4504, AS 2129 (TABLE D - E - F), AS 4087, ISO 7005-1, KS 10K																
Protection Degree		IP68 1.5 m continuous immersion (EN 60529)																
Compatible converters		MC608 A/B/R/P/I, MC406																
Electrical connections		Cable glands M20 x 1.5 + terminal block + sealing resin																

Pressure port integrated

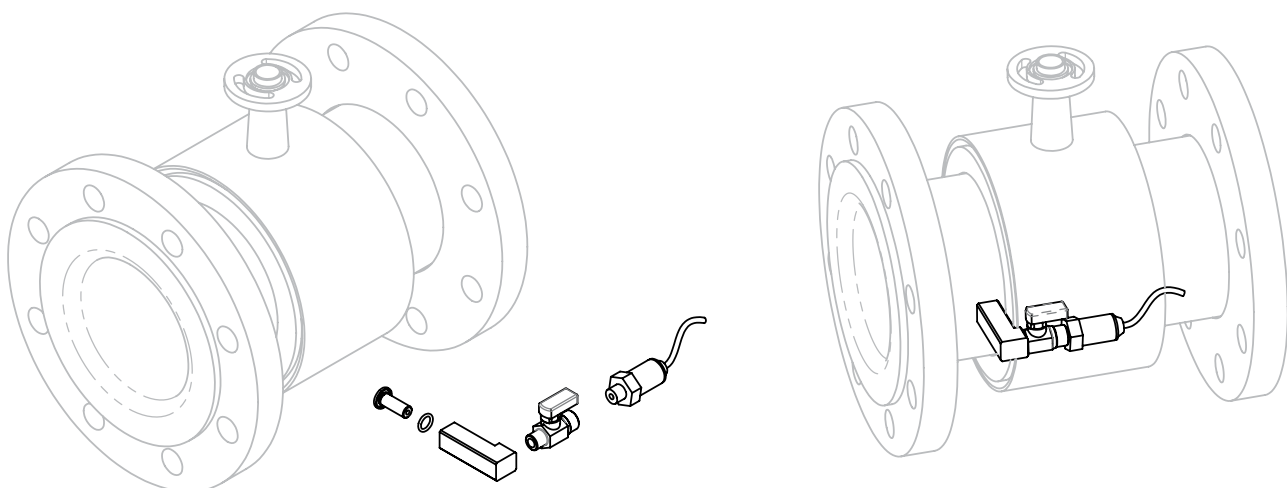

Applications

MUT2200EL sensors are suitable for any on-line application. These sensors are typically used in the measure of potable or not potable water, industrial waste water, industrial process liquids, muds and concretes.

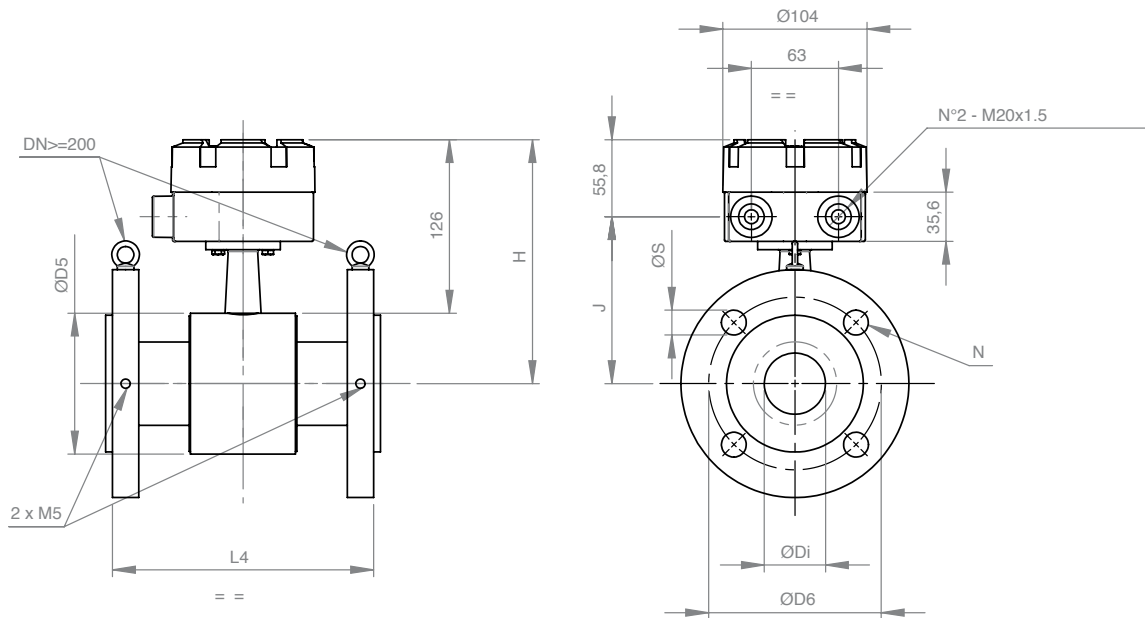

MUT 2200 EL PN10								
DN	D5	L4	J	Di	D6	N	S	H
15	84	200(+0/-3)	112.2	11.3	65	4	14	168
20	84	200(+0/-3)	112.2	16.9	75	4	14	168
25	74	200(+0/-3)	107.2	23.7	85	4	14	163
32	83	200(+0/-3)	111.7	31.8	100	4	18	167.5
40	88	200(+0/-3)	114.2	37.3	110	4	18	170
50	102	200(+0/-3)	121.2	47.3	125	4	18	177
65	114	200(+0/-3)	127.2	63.1	145	4	18	183
80	127	200(+0/-3)	133.7	74.9	160	4	18	189.5
100	161	250(+0/-3)	150.7	97	180	8	18	206.5
125	187	250(+0/-3)	163.7	122	210	8	18	219.5
150	210	300(+0/-3)	175.2	148	240	8	22	231
200	261	350(+0/-3)	200.7	195	295	8	22	256.5
250	319	450(+0/-5)	229.7	245	350	12	22	285.5
300	371	500(+0/-5)	255.7	296	400	12	22	311.5
350	404	550(+0/-5)	272.2	325.6	460	16	22	328
400	455	600(+0/-5)	297.7	374.4	515	16	25	353.5

MUT 2200 EL PN16								
DN	D5	L4	J	Di	D6	N	S	H
15	84	200(+0/-3)	112.2	11.3	65	4	14	168
20	84	200(+0/-3)	112.2	16.9	75	4	14	168
25	74	200(+0/-3)	107.2	23.7	85	4	14	163
32	83	200(+0/-3)	111.7	31.8	100	4	18	167.5
40	88	200(+0/-3)	114.2	37.3	110	4	18	170
50	102	200(+0/-3)	121.2	47.3	125	4	18	177
65	114	200(+0/-3)	127.2	63.1	145	4	18	183
80	127	200(+0/-3)	133.7	74.9	160	8	18	189.5
100	161	250(+0/-3)	150.7	97	180	8	18	206.5
125	187	250(+0/-3)	163.7	122	210	8	18	219.5
150	210	300(+0/-3)	175.2	148	240	8	22	231
200	261	350(+0/-3)	200.7	195	295	12	22	256.5
250	319	450(+0/-5)	229.7	245	350	12	25	285.5
300	371	500(+0/-5)	255.7	308	400	12	25	311.5
350	404	550(+0/-5)	272.2	339.6	470	16	25	328
400	455	600(+0/-5)	297.7	390.4	525	16	30	353.5

MUT 2200 EL PN25								
DN	D5	L4	J	Di	D6	N	S	H
15	84	200(+0/-3)	112.2	11.3	65	4	14	168
20	84	200(+0/-3)	112.2	16.9	75	4	14	168
25	74	200(+0/-3)	107.2	23.7	85	4	14	163
32	83	200(+0/-3)	111.7	31.8	100	4	18	167.5
40	88	200(+0/-3)	114.2	37.3	110	4	18	170
50	102	200(+0/-3)	121.2	47.3	125	4	18	177
65	114	200(+0/-3)	127.2	63.1	145	8	18	183
80	127	200(+0/-3)	133.7	74.9	160	8	18	189.5
100	161	250(+0/-3)	150.7	97	190	8	22	206.5
125	187	250(+0/-3)	163.7	122	220	8	25	219.5
150	210	300(+0/-3)	175.2	148	250	8	25	231
200	261	350(+0/-3)	200.7	201	310	12	25	256.5
250	319	450(+0/-5)	229.7	255	370	12	30	285.5
300	371	500(+0/-5)	255.7	306	430	16	30	311.5
350	404	550(+0/-5)	272.2	337.6	490	16	33	328
400	455	600(+0/-5)	297.7	386.4	550	16	36	353.5

MUT 2200 EL PN 40								
DN	D5	L4	J	Di	D6	N	S	H
15	84	200(+0/-3)	112.2	11.3	65	4	14	168
20	84	200(+0/-3)	112.2	16.9	75	4	14	168
25	74	200(+0/-3)	107.2	23.7	85	4	14	163
32	83	200(+0/-3)	111.7	31.8	100	4	18	167.5
40	88	200(+0/-3)	114.2	37.3	110	4	18	170
50	102	200(+0/-3)	121.2	47.3	125	4	18	177
65	114	200(+0/-3)	127.2	63.1	145	8	18	183
80	127	200(+0/-3)	133.7	74.9	160	8	18	189.5
100	161	250(+0/-3)	150.7	99	190	8	22	206.5
125	187	250(+0/-3)	163.7	124	220	8	25	219.5
150	210	300(+0/-3)	175.2	152	250	8	25	231
200	261	350(+0/-3)	200.7	199	320	12	30	256.5
250	319	450(+0/-5)	229.7	251	385	12	33	285.5
300	371	500(+0/-5)	255.7	302	450	16	33	311.5
350	404	550(+0/-5)	272.2	333.6	510	16	36	328
400	455	600(+0/-5)	297.7	382.4	585	16	39	353.5

MUT 2200 EL ANSI 150								
DN	D5	L4	J	Di	D6	N	S	H
15	84	200(+0/-3)	112.2	11.3	60.3	4	16	168
20	84	200(+0/-3)	112.2	16.9	69.8	4	16	168
25	74	200(+0/-3)	107.2	23.7	79.4	4	15.9	163
32	83	200(+0/-3)	111.7	31.8	88.9	4	15.9	167.5
40	88	200(+0/-3)	114.2	37.3	98.4	4	15.9	170
50	102	200(+0/-3)	121.2	47.3	120.6	4	19	177
65	114	200(+0/-3)	127.2	63.1	139.7	4	19	183
80	127	200(+0/-3)	133.7	74.9	152.4	4	19	189.5
100	161	250(+0/-3)	150.7	97	190.5	8	19	206.5
125	187	250(+0/-3)	163.7	122	215.9	8	22.2	219.5
150	210	300(+0/-3)	175.2	148	241.3	8	22.2	231
200	261	350(+0/-3)	200.7	195	298.4	8	22.2	256.5
250	319	450(+0/-5)	229.7	245	361.9	12	25.4	285.5
300	371	500(+0/-5)	255.7	308	431.8	12	25.5	311.5
350	404	550(+0/-5)	272.2	337.6	476.2	12	28.6	328
400	455	600(+0/-5)	297.7	388.4	539.7	16	28.6	353.5

MUT 2200 EL ANSI 300								
DN	D5	L4	J	Di	D6	N	S	H
15	84	200(+0/-3)	112.2	11.3	66.7	4	16	168
20	84	200(+0/-3)	112.2	16.9	82.5	4	19	168
25	74	200(+0/-3)	107.2	23.7	88.9	4	19	163
32	83	200(+0/-3)	111.7	31.8	98.4	4	19	167.5
40	88	200(+0/-3)	114.2	37.3	114.3	4	22.2	170
50	102	200(+0/-3)	121.2	47.3	127	8	19	177
65	114	200(+0/-3)	127.2	63.1	149.2	8	22.2	183
80	127	200(+0/-3)	133.7	74.9	168.3	8	22.2	189.5
100	161	250(+0/-3)	150.7	105	200	8	22.2	206.5
125	187	250(+0/-3)	163.7	122	234.9	8	22.2	219.5
150	210	300(+0/-3)	175.2	150	269.9	12	22.2	231
200	261	350(+0/-3)	200.7	197	330.2	12	25.4	256.5
250	319	450(+0/-5)	229.7	249	387.3	16	28.6	285.5
300	371	500(+0/-5)	255.7	300	450.8	16	31.7	311.5
350	404	550(+0/-5)	272.2	329.6	514.3	20	31.7	328
400	455	600(+0/-5)	297.7	378.4	571.5	20	34.9	353.5

MUT2200EL - MC608 A/B/R*

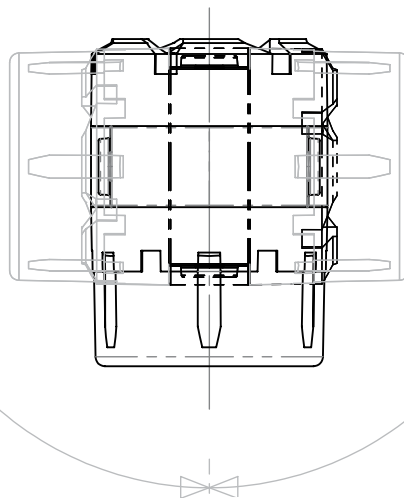
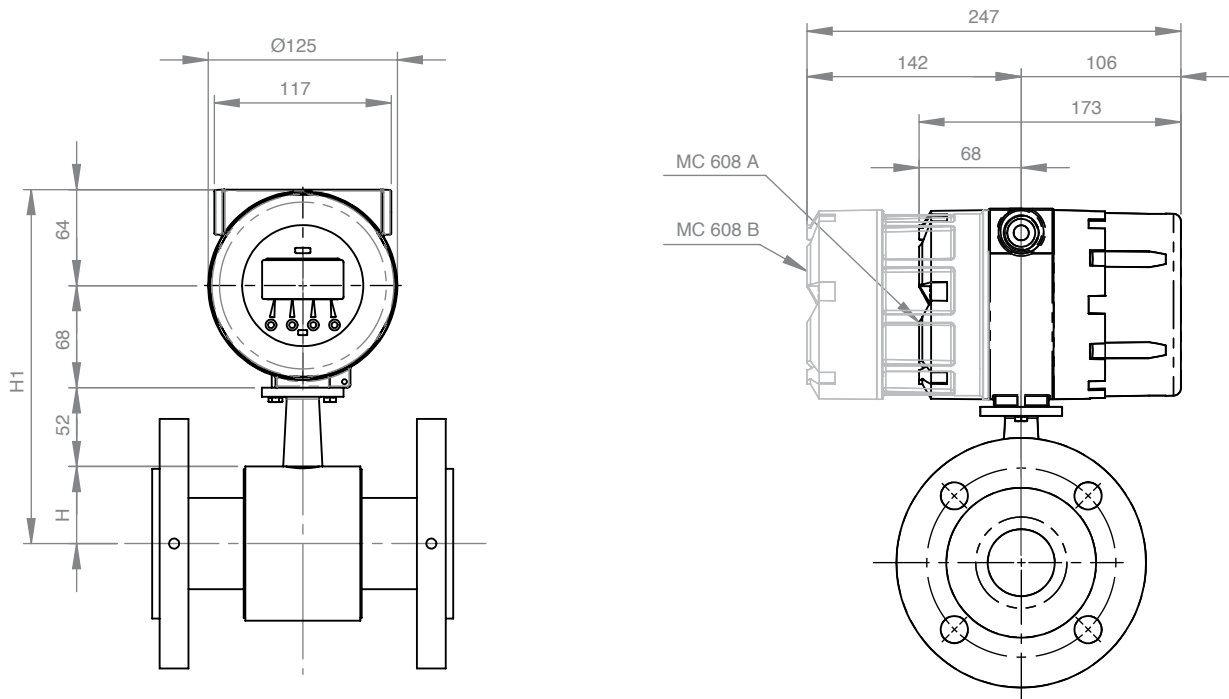

Possible rotation - upper view



MC608 A/B/R*		
DN	H	H1
25	37	220
32	42	225
40	44	227
50	51	234
65	57	240
80	64	247
100	81	264
125	94	277
150	105	288
200	131	314
250	160	343
300	186	369
350	202	385
450	260	443
500	285	468
600	342	525
700	392	575
750	417	600
800	443	626
900	498	681
1000	549	732
1200	656	839
1400	756	939
1500	806	989
1600	856	1039
1800	961	1144

* B/R max DN 600

MUT2200EL - MC406 HORIZONTAL - max DN 600

MC406 HORIZONTAL		
DN	H	H1
25	37	182
32	42	186
40	44	189
50	51	196
65	57	202
80	64	208
100	81	225
125	94	238
150	105	250
200	131	275
250	160	304
300	186	330
350	202	347
400	228	372
450	260	404
500	285	430
600	342	487

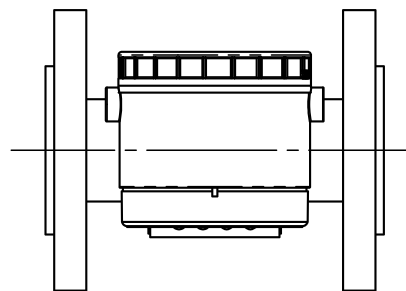
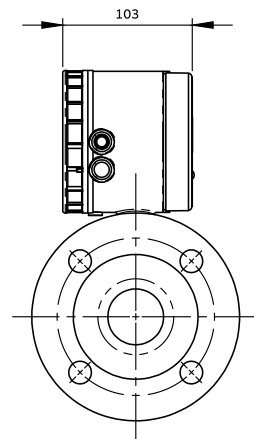
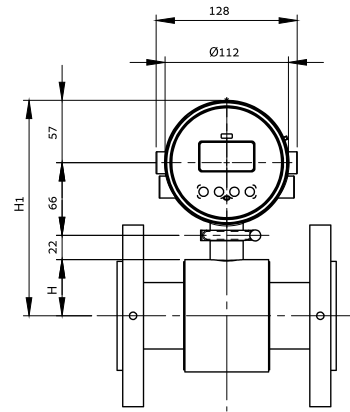

MUT2200EL - MC406 VERTICAL max DN 600

MC406 VERTICAL		
DN	H	H1
25	37	185
32	42	190
40	44	192
50	51	199
65	57	205
80	64	212
100	81	229
125	94	242
150	105	253
200	131	279
250	160	308
300	186	334
350	202	350
400	228	376
450	260	408
500	285	433
600	342	490

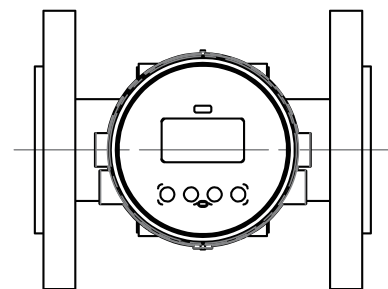
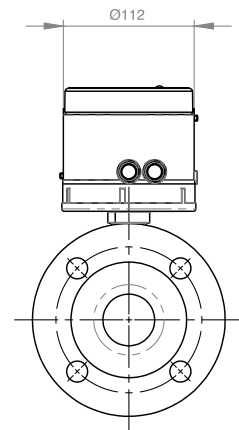
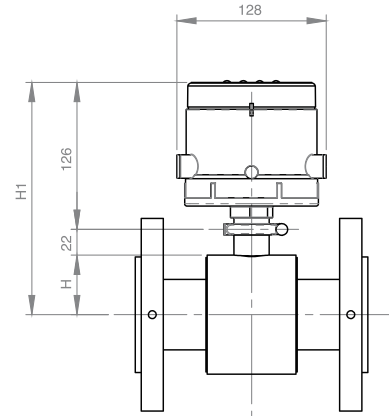

About BERMAD

BERMAD is a leading, privately-owned global company that designs, develops and manufactures tailor-made water & flow management solutions that include state-of-the-art hydraulic control valves, air valves and advanced metering solutions.

Founded in 1965, we have spent over 50 years interacting with the world's major end users,

and accumulating knowledge and experience in multiple markets and industries. Today, we are recognized as a pioneer and established world-leading provider of water & flow management solutions that give our customers the unprecedented operational efficiency, and superior quality, durability and performance they need to meet the demanding challenges of the 21st century.

ozbranding.co.il



www.bermad.com

The information contained herein may be changed by BERMAD without notice. BERMAD shall not be held liable for any errors.
© Copyright 2009-2019 BERMAD CS Ltd. PCUAE19-MUT2200EL