

Butterfly Valves / Duo-check valves

www.ancvalve.co.kr



ANC VALVE

Rubber Lined Butterfly Valve



100% Bi-directional tight shut off at full rated pressure

Valve Type

- WAFER - SRS710 Rubber Lined Butterfly Valves
- LUG - SRS711 Rubber Lined Butterfly Valves
- FLANGE - SRS712 Rubber Lined Butterfly Valves

Standard Compliance

- Conform to MSS SP67, API 609, EN593, in general.

Production Range

- Size : DN 50 to DN 3000 (2 inch - 120 inch)
- Working Pressure : Up to 16 bar
- Working Temperature : -20 °C - +160 °C

Connection Flange

- ANSI B16.1 CL. 125LB & B16.5 CL.150LB / MSS SP44 CL.150LB
- AS2129 Table D & E / EN 1092 PN6, PN10 & PN16
- BS10 Table D & E / DIN2501 PN6, PN10 & PN16
- ISO 7005 PN6, PN10 & PN16 / KS B 1511/JIS B 2210 5K, 10K&16K
- SABS 1123 Table 1000/3 & Table 1600/3

Face to Face Dimensions

- Conform to EN 558, ISO 5752, MSS SP67, JIS B2032, and AP1609.

Application

- | | | |
|---------------------------|------------------------|----------------------------------|
| •Air Conditioning | •Shipbuilding Industry | •Paper Industry |
| •Air Line | •Drilling Rigs | •Sand Handling |
| •Water Works | •Dry Powder | •Sugar Industry |
| •Ballast and Bilge system | •Food and Beverage | •Waste Water |
| •Chemical Processing | •Gas Plant | •Water and Others |
| •Power Plants | •Heating Line | •Thermo Technical Watertreatment |
| •Desalination Plants | •Mining Industry | |

Rubber Lined Butterfly Valve

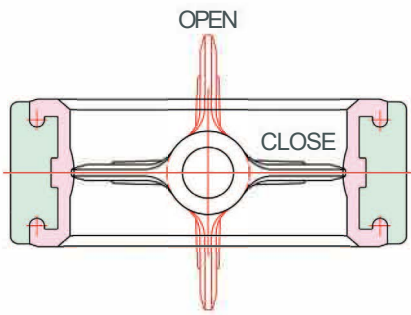

General Features

- 100% bi-directional tight shut off.
- Installation without restriction in direction of flow.
- Reduced weight and overall dimensions.
- Low pressure loss and reduced energy costs.
- High Kv / Cv values.
- Easy to clean and disinfect for portable water systems etc.
- Self cleaning (No residue will be trapped).
- Good resistance to corrosion.
- High reliability

No Screw between Disc and Shaft

The disc and shaft connection features all of the benefits of a high strength 2 piece design with the disadvantage associate with designs using taper pins or disc screws which often fail through abrasion, corrosion of fatigue. The disc edge is spherically machined and hand polished to produce a bubble-tight shut off minimum torque and longer seat life.

No Gasket required

O-rings or gaskets are not required when installation.

Low Torque

Valve discs are spherical machined and polished. Every parts of sealing surface is spherical. These fit together with a smooth and low torque when close and open. The raised center seat has the cosine-curve structure.

Perfect Sealing

Seat and disc is sealed as flat surface matched both top and bottom shaft point. This unique sealing gives perfect tight at low torque and smooth touch.

Top Flange

It is in accordance with ISO5211 and it matches with any type of actuators.

Testing

Butterfly valves are confirmed to API 598 and BS51 55. Body pressure test to be done 150% and shell to be 110% of maximum working pressure.

Operations

- Bare stem type
- Gear
- Pneumatic actuator
- Lever
- Electric motor actuator
- Hydraulic actuator

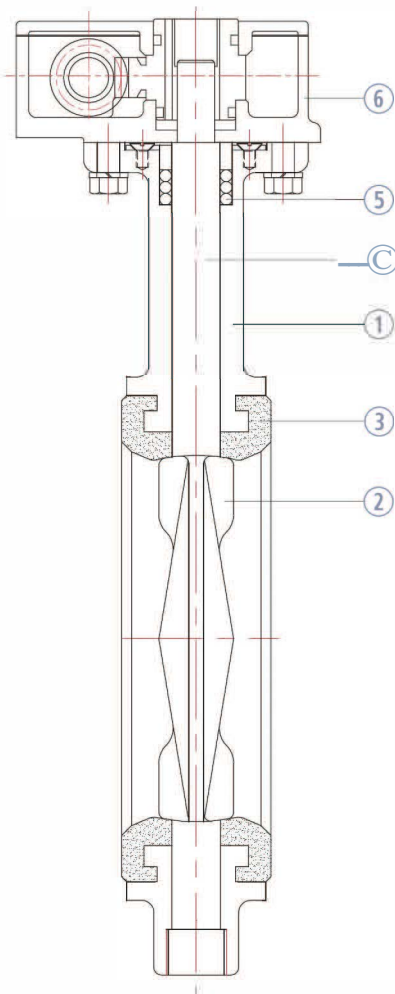

P. No.	PART NAME	MATERIAL
1	BODY	CAST IRON / DUCTILE IRON CARBON STEEL/ STAINLESS STEEL (55304 / 55316) BRONZE / ALUMINUM BRONZE / NI-ALUMINUM BRONZE
2	DISC	DUCTILE IRON(+NICKEL PLATED) CARBON STEEL(+NICKEL PLATED)/ ALUMINUM BRONZE STAINLESS STEEL(SS304 / 55316)
3	SEAT	RUBBER (NBR / SILICON / EPDM / VITON / NEOPRENE)
4	STEM	STAINLESS STEEL (55410 / 55304 / 55316 / 55630 / MONEL)
5	PACKING	NBR. RUBBER
6	ACTUATOR	BARE/ LEVER/ GEAR/ MOTOR/ PNEUMATIC / HYDRAULIC ETC

SRS 710 - WAFER TYPE Rubber Lined Butterfly Valve

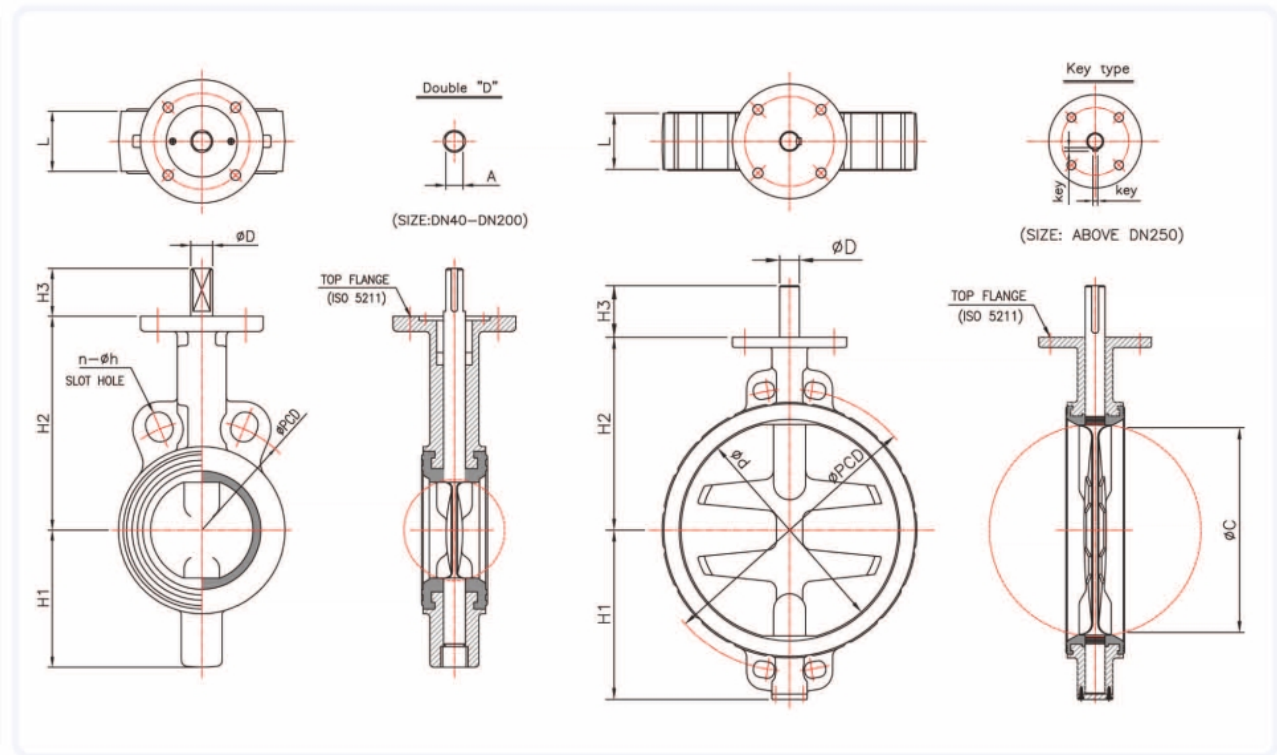

Dimensions

unit: mm

SIZE		ϕd	L	H1	H2	H3	STEM		TOP FLANGE (ISO 5211)	JIS 10K			ANSI 150LB			EN 1092 PN10			WEIGHT (APPROX) kg	
inch	mm						ϕD	KEY		ϕPCD	n	h	ϕPCD	n	h	ϕPCD	n	h		
40	40	40	40	54	120	33	14	FL'10	F07	70	105	4	19	98.5	4	16	110	4	19	2.7
2	50	52	43	70	130	33	14	FL'10	F07	70	120	4	19	120.5	4	19	125	4	19	2.9
2.5	65	64	46	75	135	33	14	FL'10	F07	70	140	4	19	139.5	4	19	145	4	19	4.1
3	80	76	46	90	150	33	16	FL'12	F07	70	150	8	19	152.5	4	19	160	8	19	4.4
4	100	101	52	105	170	33	16	FL'12	F07	70	175	8	19	190.5	8	19	180	8	19	4.7
5	125	126	56	120	186	33	19	FL'15	F07	70	210	8	23	216.0	8	22	210	8	19	6.3
6	150	149	56	135	200	33	19	FL'15	F07	70	240	8	23	241.5	8	22	240	8	23	7.9
8	200	196	60	168	238	33	22	FL'18	F07	70	290	12	23	298.5	8	22	295	8	23	12.3
10	250	244	68	203	270	50	22	8 X 7	F10	102	355	12	25	362.0	12	25	350	12	23	19.2
12	300	294	78	242	310	50	28	8 X 7	F10	102	400	16	25	432.0	12	25	400	12	23	30.2
14	350	333	78	280	340	50	28	8 X 7	F10	102	445	16	25	476.0	12	29	460	16	23	55.0
16	400	384	102	302	378	60	38	12X8	F14	160	510	16	27	539.5	16	29	515	16	28	80.0
18	450	435	114	320	400	60	38	12X8	F14	160	565	20	27	578.0	16	32	565	20	28	110.0
20	500	485	127	370	435	80	45	14X9	F16	165	620	20	27	635.0	20	32	620	20	28	145.0
22	550	534	142	396	485	80	55	14X9	F16	165	680	20	M30	392.2	20	1 1/4	-	-	-	200.0
24	600	573	154	430	500	80	55	14X9	F16	165	730	24	M30	749.5	20	1 1/4	725	20	M27	235.0
26	650	624	165	463	530	80	55	14X9	F16	165	780	24	M30	806.5	24	1 1/2	-	-	-	310.0
28	700	674	165	500	580	110	65	18X11	F16	165	840	24	M30	863.5	28	1 1/4	840	24	M27	330.0
30	750	716	190	520	590	110	65	18X11	F25	254	900	24	M30	914.4	28	1 1/2	-	-	-	385.0
32	800	767	190	565	630	110	75	20X12	F25	254	950	28	M30	977.9	28	1 1/2	950	24	M30	460.0
34	850	824	200	620	660	140	72	20X12	F25	254	1000	28	M30	1028.7	32	1 1/2	-	-	-	565.0
36	900	860	203	670	700	150	80	22X14	F25	254	1050	28	M30	1085.9	32	1 1/2	1050	28	M30	630.0
40	1000	970	216	725	750	150	90	25X14	F25	254	1160	28	M36	1200.2	36	1 1/2	1160	28	M33	25.0
42	1050	1010	216	750	820	140	90	25X14	F25	254	-	-	-	1257.3	36	1 1/2	-	-	-	860.0
48	1200	1173	254	860	900	150	90	25X14	F25	254	1380	32	M36	1422.0	44	1 1/2	1380	32	M36	910.0

* Specification and design are subject to change without notice

SRS 711 - LUG TYPE Rubber Lined Butterfly Valve

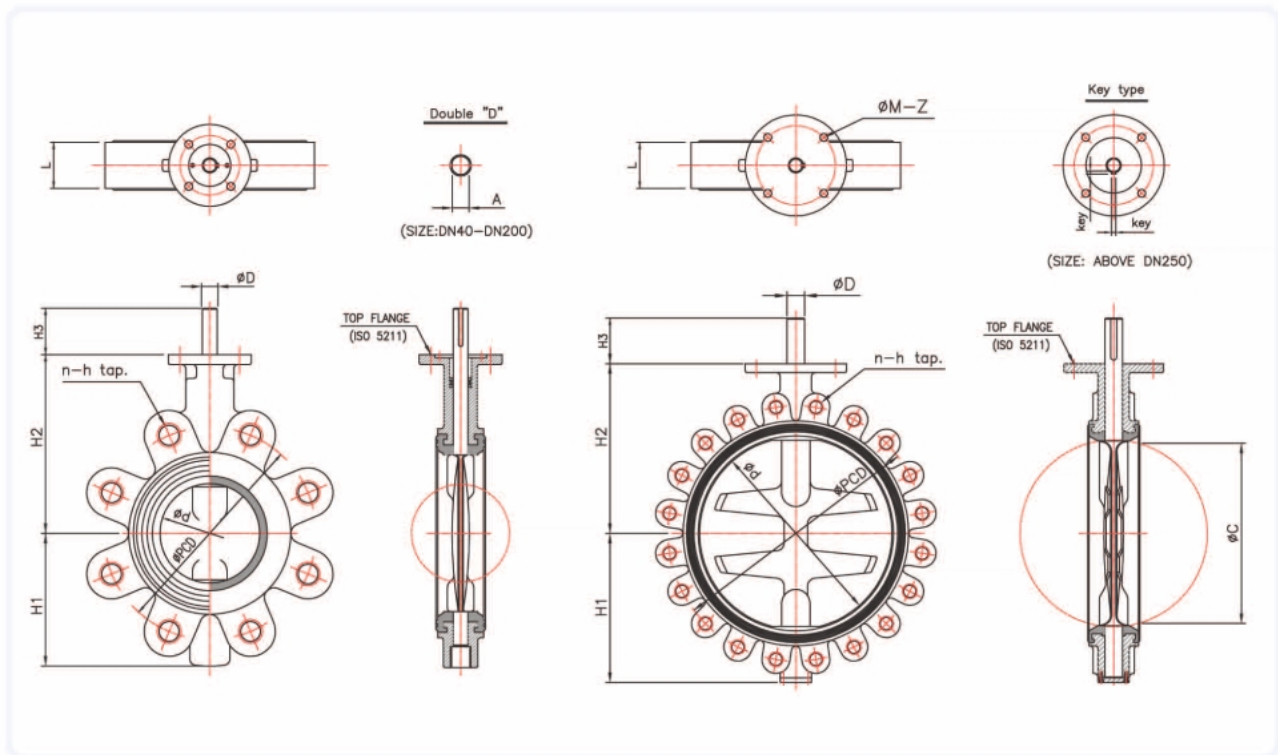

Dimensions

unit: mm

SIZE		Ød	L	H1	H2	HB	STEM		TOP FLANGE (ISO 5211)	JIS 10K			ANSI 150LB			EN 1092 PN10			WEIGHT (APPROX) kg
inch	I mm						ØD	KEY		ØPCD	n	I	h	ØPCD	n	h	ØPCD	n	
1 1/2	40	40	40	54	120	33	14	FL'10	F07 70	105	4	M16	98.5	4	1/2	110	4	M16	3.7
2	50	52	48	70	130	33	14	FL'10	F07 70	120	4	M16	120.5	4	5/8	125	4	M16	4.2
2.5	65	64	46	75	135	33	14	FL'10	F07 70	140	4	M16	139.5	4	5/8	145	4	M16	5.7
3	80	76	46	90	150	33	16	FL'12	F07 70	150	8	M16	152.5	4	5/8	160	8	M16	8.7
4	100	101	52	105	170	33	16	FL'12	F07 70	175	8	M16	190.5	8	3/4	180	8	M16	9.2
5	125	126	55	120	186	33	19	FL'15	F07 70	210	8	M20	216.0	8	3/4	210	8	M16	12.7
6	150	149	55	135	200	33	19	FL'15	F07 70	240	8	M20	241.5	8	3/4	240	8	M20	13.7
8	200	195	60	168	238	33	22	FL'18	F07 70	290	12	M20	298.5	8	7/8	295	8	M20	22.0
10	250	244	68	203	270	50	22	8 X 7	F10 102	355	12	M22	362.0	12	7/8	350	12	M20	28.0
12	300	294	78	242	310	50	28	8 X 7	F10 102	400	16	M22	432.0	12	1	400	12	M20	45.0
14	350	333	78	280	340	50	28	8 X 7	F10 102	445	16	M22	476.0	12	1	460	16	M20	74.0
16	400	384	102	302	378	60	38	12X8	F14 160	510	16	M24	539.5	16	1 1/8	515	16	M24	113.0
18	450	435	114	320	400	60	38	12X8	F14 160	555	20	M24	578.0	16	1 1/8	555	20	M24	145.0
20	500	485	127	370	435	80	45	14X9	F16 165	620	20	M24	635.0	20	1 1/4	620	20	M24	215.0
22	550	534	142	396	485	80	55	14X9	F16 165	680	20	M30	392.2	20	1 1/4	-	-	-	275.0
24	600	573	154	430	500	80	55	14X9	F16 165	730	24	M30	749.5	20	7/8	725	20	M27	345.0
26	680	624	165	463	530	80	55	14X9	F16 165	780	24	M30	806.5	24	1 1/4	-	-	-	430.0
28	700	674	165	500	580	110	65	18X11	F16 165	840	24	M30	863.5	28	1 1/4	840	24	M27	475.0
30	750	716	190	520	590	110	65	18X11	F25 254	900	24	M30	914.4	28	1 1/4	-	-	-	610.0
32	800	767	190	565	630	110	75	20X12	F25 254	950	28	M30	977.9	28	1 1/2	950	24	M30	715.0
34	850	824	200	620	660	140	75	20X12	F25 254	1000	28	M30	1028.7	32	1 1/2	-	-	-	760.0
36	900	880	203	670	700	140	80	22X14	F25 254	1050	28	M30	1085.9	32	1 1/2	1050	28	M30	830.0
40	1000	970	216	725	750	140	90	22X14	F25 254	1160	28	M36	1200.2	36	7/2	1160	28	M33	990.0
42	1050	1010	216	750	820	140	90	25X14	F25 254	-	-	-	1257.3	36	1 1/2	-	-	-	1215.0
48	1200	1173	254	880	900	140	90	22X14	F25 254	1380	32	M36	1422.0	44	7/2	1380	32	M36	1450.0

* Specification and design are subject to change without notice

SRS 712 - FLANGE TYPE Rubber Lined Butterfly Valve

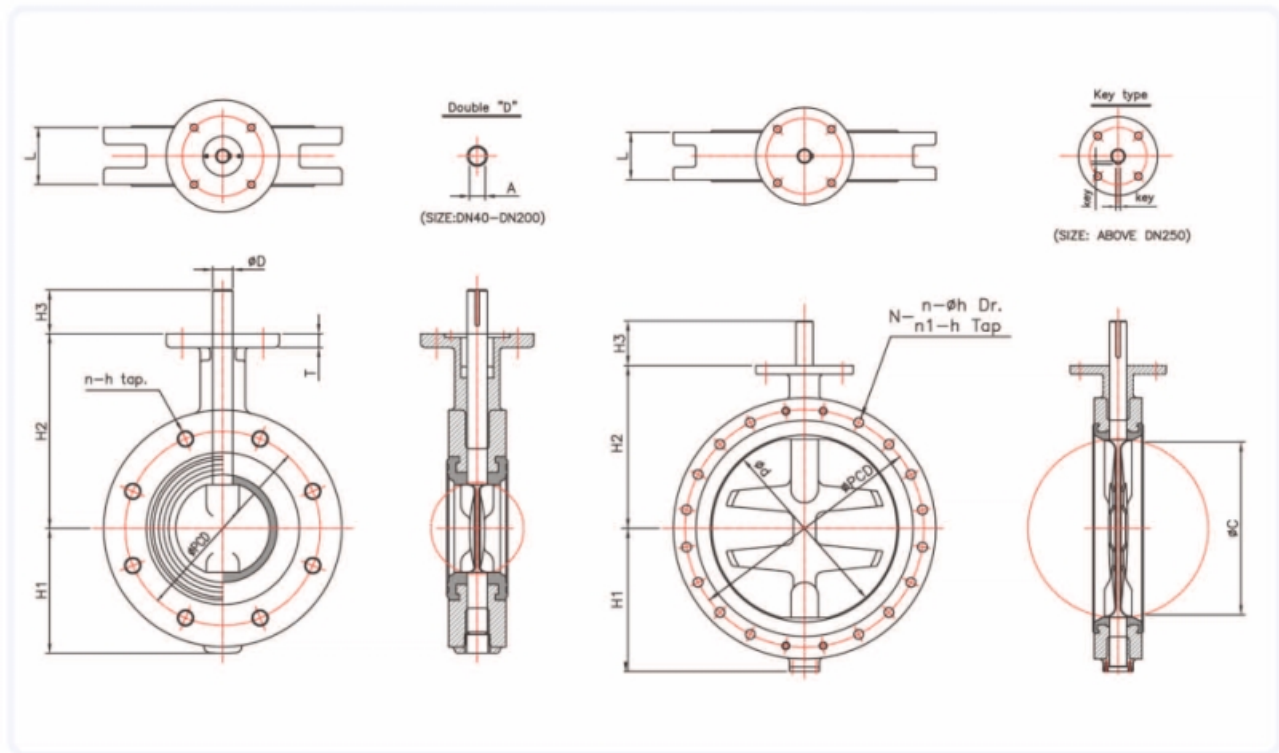

Dimensions

unit: mm

SIZE	inch	l	mm	Ød	H1		H2	H3	STEM		TOP FLANGE (ISO 5211)	JIS 10K			ANSI 150LB			EN 1092 PN10			WEIGHT [APPROX] [kg]	
					Short	Long			ØD	KEY		ΦPCD	n	h	ΦPCD	n	h	ΦPCD	n	h		
1 1/2	40	40	40	40	40	54	120	33	14	FL'10	F07	70	105	4	M16	98.5	4	1/2	110	4	M16	6.0
2	50	52	43	40	70	130	33	14	FL'10	F07	70	120	4	M16	120.5	4	5/8	125	4	M16	6.5	
2.5	65	64	46	40	75	135	33	14	FL'10	F07	70	140	4	M16	139.5	4	5/8	145	4	M16	9.0	
3	80	76	46	60	90	150	33	16	FL'12	F07	70	150	8	M16	152.5	4	5/8	160	8	M16	10.0	
4	100	101	52	60	105	170	33	16	FL'12	F07	70	175	8	M16	190.5	8	3/4	180	8	M16	14.0	
5	125	126	56	100	120	186	33	19	FL'15	F07	70	210	8	M20	216.0	8	3/4	210	8	M16	16.5	
6	150	149	56	100	135	200	33	19	FL'15	F07	70	240	8	M20	241.5	8	3/4	240	8	M20	19.0	
8	200	196	60	100	168	238	33	22	FL'18	F07	70	290	12	M20	298.5	8	7/8	295	8	M20	32.0	
10	250	244	68	110	203	270	50	22	8 X 7	F10	102	355	12	M22	362.0	12	7/8	350	12	M20	46.0	
12	300	294	78	110	242	310	50	28	BX 7	F10	102	400	16	M22	432.0	12	1	400	12	M20	58.0	
14	350	333	78	120	280	340	50	28	8 X 7	F10	102	445	16	M22	476.0	12	1	460	16	M20	94.0	
16	400	384	102	130	302	378	60	38	12X8	F14	160	510	16	M24	539.5	16	1 1/8	515	16	M24	130.0	
18	450	435	114	150	320	400	60	38	12X8	F14	160	565	20	M24	578.0	16	1 1/8	565	20	M24	160.0	
20	500	485	127	160	370	435	80	45	14X9	F16	165	620	20	M24	635.0	20	1 1/4	620	20	M24	215.0	
22	550	534	142	170	396	485	80	55	14X9	F16	165	680	20	M30	392.2	20	1 1/4	-	-	-	280.0	
24	600	573	154	170	430	500	80	55	14X9	F16	165	730	24	M30	749.5	20	1 1/4	725	20	M27	335.0	
26	650	624	165	170	463	530	80	55	14X9	F16	165	780	24	M30	806.5	24	1 1/4	-	-	-	420.0	
28	700	674	165	180	500	580	110	65	18X11	F16	165	840	24	M30	863.5	28	1 1/4	840	24	M27	470.0	
30	750	716	190	190	520	590	110	65	18X11	F25	254	900	24	M30	914.4	28	1 1/4	-	-	-	585.0	
32	800	767	190	200	565	630	110	75	20X12	F25	254	950	28	M30	977.9	28	1 1/2	950	24	M30	700.0	
34	850	824	200	210	620	660	140	75	20X12	F25	254	1000	28	M30	1028.7	32	1 1/2	-	-	-	745.0	
36	900	860	203	230	670	700	140	80	25X14	F25	254	1050	28	M30	1085.9	32	1 1/2	1050	28	M30	810.0	
40	1000	970	216	250	725	750	140	90	25X14	F25	254	1160	28	M36	1200.2	36	1 1/2	1160	28	M33	960.0	
42	1050	1010	216	280	750	820	140	90	25X14	F25	254	-	-	-	1257.3	36	1 1/2	-	-	-	1000.0	
48	1200	1173	254	300	860	900	140	90	25X14	F25	254	1380	32	M36	1422.0	44	1 1/2	1380	32	M36	1265.0	

* Specification and design are subject to change without notice

Torque Required to Operate



Torque Table

unit: kg.m/Nm/in-lb

SIZE		Working Pressure (bar)											
		3 bar			5 bar			10 bar			16 bar		
mm	inch	kg-m	Nm	in-lb	kg-m	Nm	in-lb	kg-m	Nm	in-lb	kg-m	Nm	in-lb
50A	2	12	11.7	104	15	14.7	130.1	18	17.6	156.1	23	22.5	199.5
65A	2 1/2	15	14.7	130.1	18	18.3	162.6	25	24.5	216.8	27	26.4	234.1
80A	3	25	24.5	216.8	27	27.6	240	3	29.4	260.2	35	34.3	303.5
100A	4	35	34.3	303.5	43	42.8	379.4	5	49	433.6	5	49	433.6
125A	5	5	49	433.6	62	61.2	542.1	65	63.7	563.7	8	78.4	693.9
150A	6	8	78.4	693.9	10	98	867.3	12	117.6	1040	15	147	1300
200A	8	14	137.2	1214.3	16	156.8	1387.8	18	176.4	1561.2	24	235.2	2081.7
250A	10	23	225.4	1994.9	26	254.9	2256	29	284.2	2515.3	36	352.8	3122.5
300A	12	31	303.8	2688.8	34	333.2	2949	38	519.4	4597	72	705.6	6245
350A	14	45	441	3903.1	50	490	4336.8	63	617.4	5464.4	115	1127	9974.8
400A	16	61	597.8	5290.9	70	686	6071.6	80	784	6938.9	144	1411.2	12490.1
450A	18	81	793.8	7025.7	92	901.6	7979.8	117	1146.6	10148.2	190	1852	16480.1
500A	20	106	1038.8	9194.1	120	1176	10408.4	150	1470	13010.6	220	2156	19082.2
550A	22	130	1274	11275.8	162.5	1592.5	14094.8	181	1773.8	15699.4	295	2891	25587.5
600A	24	221	2165.8	19168.9	240	2352	20816.9	260	2548	22551.7	355	3479	30791.7
650A	26	182	1783.6	15786.2	245	2401	21250.6	288	2822.4	24980.3	345.6	3386.8	29976.4
700A	28	215	2107	18648.5	315	3087	27322.2	355	3479	30791.7	426	4174.8	36950.1
750A	30	255	2499	22118	342	3351.6	29664.1	390	3822	33827.5	468	4586.4	40593
800A	32	290	2842	25153.8	405	3969	35128.6	460	4508	39899.1	552	5409.6	47879
850A	34	325	3185	28189.6	495	4851	42934.9	538	5272.4	46664.6	645.6	6326.8	55997.6
900A	36	405	3969	35128.6	578	5664.4	50134.1	660	6468	57246.6	792	7761.6	68695.9
1000A	40	565	5537	49006.6	880	8624	76328.8	1050	10290	91074.2	1260	12348	109289
1200A	48	968	9486	83961	1210	11858	104952	1760	17248	152657	2110	21658	191689
1350A	54	1135	11123	98446	1400	13720	121432	2024	19835	175556	2211	21667	191776
1800A	72	1970	19306	170872	2260	22148	196026	2780	27244	241129	3813	37367	330729
3000A	120	10500	102900	910742	12367	121196	1072680	20850	204330	1808473	28630	280574	2483290
4000A	160	39800	390040	3452146	41500	406700	3599600	48850	478730	4237119	67300	659540	5837423

The operating speed of the actuator must be considered in order to avoid water hammer when the valve is closed in junction with Liquid.

The factors affect the torque required to operate Butterfly valves.

- Valve Diameter
- Shaft Diameter
- Bearing Friction Coefficient
- Type of Seat Material
- Shutoff Pressure
- Velocity
- Shape of Disc
- System Head Characteristics
- Piping Arrangement

Actuator torque can be calculated using the following formulas.

$T_a = T_b + T_s + T_h = 1.2T_b \pm T_d$ $T_s = C_s D^2$ $T_b = 4.17 D^2 d f P$ $T_d = C_t D^3 P$ $T_h = 3.06 D^4$ $V = C_f \sqrt{P} = \frac{Q}{0.785 D^2}$	<p>T_a : The required actuator torque(lb-ft)</p> <p>T_s : Seating or unseating torque(lb-ft)</p> <p>T_d : Dynamic torque(lb-ft)</p> <p>T_h : Hydrostatic torque(lb-ft)</p> <p>Q : Flow(cubic foot per second)</p> <p>V : Velocity (feet per second)</p> <p>D : Diameter of valve(feet)</p>	<p>d : Diameter of Shaft(inch)</p> <p>P : Pressure drop across valve (psi)</p> <p>C_s : Coefficient of Seating/unseating torque</p> <p>C_t : Coefficient of dynamic torque</p> <p>C_f : Coefficient of flow</p> <p>f : Bearing friction coefficient</p>
---	--	---

Basic Formulas for obtaining Cv-Value

Cv is in imperial units, the water flow in U.S. gallons per minute which passes through the valve giving a pressure drop of 1 PSI at a temperature of 68 °F

In metric units the same coefficient is called Kv and correspond to the flow rate in m³/h passing through the valve giving a pressure drop of 1bar at a temperature of 20 °C

The approximate corresponding formulas are:

$$Q = C_v \cdot \sqrt{(\Delta P \cdot 62.4/D)}$$

$$Q = K_v \cdot \sqrt{(\Delta P \cdot 1000/D)}$$

Where:

Q = valve flow rate in gpm (USGPM)

ΔP = pounds per square inch (psi) pressure drop through the valve

62.4 = conversion factor for fluids computed in relation to water

D = is pounds per cu.ft (pct) fluid density

Where :

Q = valve flow rate in m³/h

ΔP = pressure drop through the valve in bar

1000 = conversion factor for fluids computed in relation to water

D = kg /m³ fluid density

The relation between Cv and Kv, expressed in the above mentioned unit of measure is as follows :

$$C_v = 1.16 K_v$$

Flow coefficient

SIZE		DISC OPENING															
		20 °		30 °		40 °		50 °		60 °		70 °		80 °		90 °	
inch	mm	Kv	Cv	Kv	Cv	Kv	Cv	Kv	Cv	Kv	Cv	Kv	Cv	Kv	Cv	Kv	Cv
2	50	10	11.6	15.1	17.5	23.5	27.3	38.4	44.6	62.1	72	100	116	154.3	179	184.5	214
2.5	65	16.9	19.6	25.5	29.6	39.7	46	64.7	75	105.2	122	169.8	197	260.3	302	312.1	362
3	80	25.6	29.7	38.6	44.8	60.3	70	98.3	114	158.6	184	256.9	298	394.8	458	472.4	548
4	100	39	45	60	70	94	109	153	178	249	289	402	466	616	715	738	856
5	125	63	73	94	109	147	171	240	278	387	449	628	728	964	1118	1153	1338
6	150	90	104	136	158	212	246	346	401	560	650	903	1048	1388	1610	1661	1927
8	200	160	186	241	280	377	437	615	713	996	1155	1606	1863	2467	2862	2953	3426
10	250	250	290	378	438	588	682	960	1114	1556	1805	2509	2911	3855	4472	4615	5353
12	300	360	418	543	630	847	983	1383	1604	2241	2599	3614	4192	4689	5439	6645	7708
14	350	491	569	740	858	1153	1338	1882	2183	3037	3523	4918	5705	7555	8764	9044	10491
16	400	641	743	966	1121	1506	1747	2459	2852	3983	4620	6424	7452	9868	11447	11813	13703
18	450	810	940	1222	1418	1906	2211	3111	3609	5041	5847	8130	9431	12490	14488	14951	17343
20	500	1001	1161	1509	1751	2353	2730	3841	4456	6223	7219	10038	11644	15419	17886	18458	21411
22	550	1211	1405	1827	2119	2847	3303	4647	5391	7501	8701	12146	14089	18657	21642	22334	25907
24	600	1441	1672	2174	2522	3389	3931	5531	6416	8961	10395	14454	16767	22203	25756	26579	30832
26	650	1691	1962	2552	2960	3978	4614	6491	7530	10476	12152	16964	19678	26058	30227	31193	36184
28	700	1961	2275	2959	3432	4613	5351	7528	8733	12150	14094	19673	22821	30222	35057	36177	41965
30	750	2252	2612	3397	3940	5295	6142	8642	10025	14002	16242	22584	26198	34693	40244	41530	48175
32	800	2562	2972	3865	4483	6025	6989	9833	11406	15869	18408	25696	29807	39472	45788	47252	54812
34	850	2892	3355	4363	5061	6802	7890	11100	12876	17915	20781	29009	33650	44561	51691	53343	61878
36	900	3242	3761	4891	5674	7625	8845	9859	11436	20163	23389	32522	37725	49958	57951	59803	69371
38	950	3613	4191	5450	6322	8496	9855	13866	16084	22378	25958	36235	42033	55663	64569	66632	77293
40	1000	4003	4643	6039	7005	9414	10920	15364	17822	24796	28763	40150	46574	61676	71544	73831	85644
42	1050	4413	5119	6658	7723	10497	12176	16939	19649	27337	31711	44266	51348	67997	78877	81398	94422
44	1100	4843	5618	7307	8476	11391	13213	18591	21565	30003	34803	48582	56355	74628	86568	89335	103629
46	1150	5294	6141	7986	9264	12449	14441	20319	23570	32792	38039	53098	61594	81566	94617	97641	113264
48	1200	5761	6683	8696	10087	13556	15725	22124	25664	35706	41419	57816	67067	88814	103024	106316	123327
54	1350	6006	6967	9061	10511	14126	16386	23055	26744	37208	43162	60250	69890	92552	107360	110792	128519
72	1800	12540	14546	18918	21945	29491	34210	48133	55834	77682	90111	125786	145991	193224	214140	226106	262283
160	4000	62770	72813	94695	109846	147620	171240	240929	279478	388834	451047	629617	730356	967177	1121926	1157784	1343030



Storage of Valves

Store the **valve** in dry, dark and cool conditions, preferably indoors with the actual **valve** temperature higher than the dew point.

If outdoor storage is unavoidable, support the **valves** off the ground and protect the **valves** with a watertight cover.

Do not remove the **valve** packaging or end port protection, until necessary for inspection or installation. Store the **valve** in the slightly open position to avoid deformation of the rubber lining.

Installation Instructions

General

Before shipment, the seat surface is lubricated with silicone grease. If it is considered not necessary for special usage, it can be removed with solvent. In case **valves** are for chlorine, oxygen hydrogen, **valves** should be cleaned and degreased perfectly. Valves can be installed in the pipeline in any position.

Before installation of **valves**, the pipeline must be cleaned from dirt and welding residues. Otherwise seat may be damaged. Pipes must be free of tension.

Wafer and lug type butterfly **valves** can be installed directly in between flanges without any gaskets.

Installation in line related to wafer butterfly **valve** (on the existing pipeline)

- Verify the distance between two flanges to be equal to face to face **valve** dimension.
- In order to facilitate installation of the **valve**, allow a sufficient room with adequate tools in between two flanges.
- Insert the lower part of flanges at least two flange-bolts.
- Close **valve** disc partially so that disc edge is at least 10mm within the body.
- Insert **valve** in between two flanges. Valve will be held by the two flange-bolts previously fitted in the lower part of flanges.
- Insert the flange-bolts through centering lugs of **valve**.
- Insert the remaining flange-bolts aligning the **valve** with the flanges and tightening flange-bolts manually.
- Maintain the **valve** aligned, remove gradually flange spreaders and tighten bolts partially.
- Control open and close operation of **valve** to be easy and smooth.
- Open the **valve** completely and cross tighten the bolts to adequate torque.

Installation of lug type butterfly **valve** has the same procedure with wafer type except using cap screws instead of bolts and nuts.

Installation in line related to wafer butterfly **valve** (on the new pipeline)

- Shut partially **valve** disc until disc profile is at least 10mm within the body.
- Align the two flanges with the **valve** body.
- Span the body with some flange-bolts and tighten the bolts partially. Finish tightening by uniform cross bolting.
- Use the flange-valve-flange unit for pipe centering.
- Tack-weld the flanges to the pipe.
- Remove the bolting and the **valve** from the flanges. Just perform tack-welding only when the **valve** is inserted, as high heat temperature can damage **valve** seat.
- Weld flanges to the pipe and wait until completely cooled down.
- Install the **valve** by applying the same instruction procedure as the installation instruction on the existing pipeline.

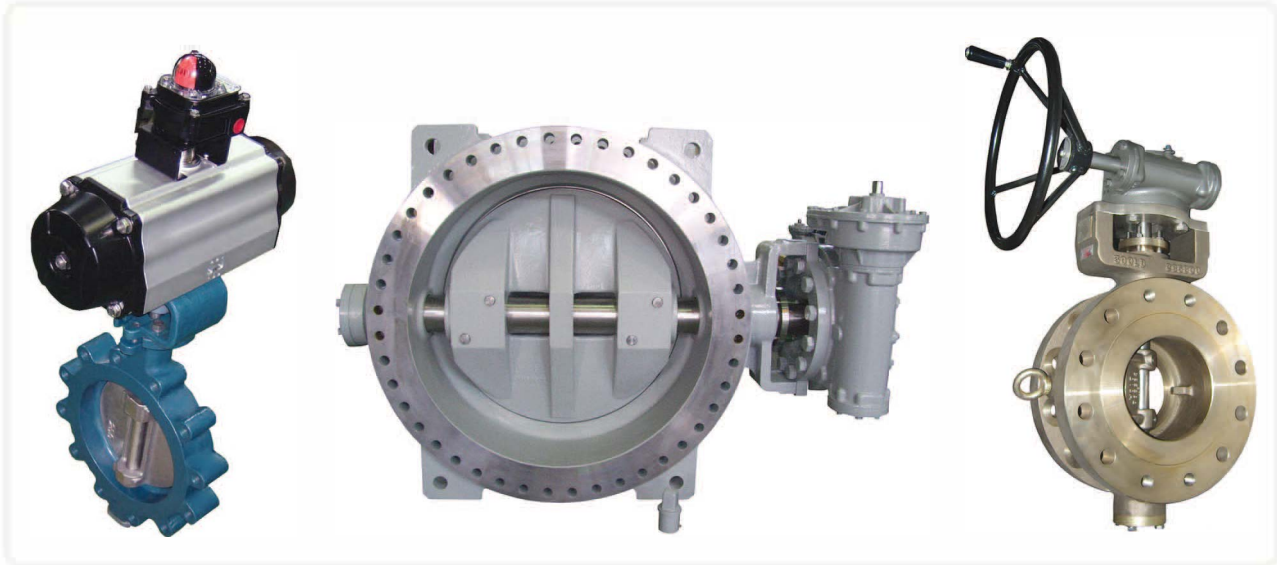

Valve Type

- WAFER - SRS720 Double & Triple Offset metal seated butterfly valves
- LUG - SRS721 Double & Triple Offset metal seated butterfly valves
- FLANGE - SRS722 Double & Triple Offset metal seated butterfly valves

Standard Compliance

- Conform to API 609, EN593 and MSS SP 67
- Fire Safe requirement meets BS 6755 part 2 / API6FA and API Std 607 4th edition.

Production Range

- Size : 50mm(2inch) - 3000mm (120 inch)
- Working Pressure : Maximum 2220psi (156 bar)
 - upto 156 bar for DN 80 - DN 600
 - upto 114 bar for DN 650 - DN 1000
 - upto 22 bar for DN 1200 - DN 2000
- Working Temperature: -196° C - +700° C

Connection Flange

- EN1092 PN10, PN16, PN25, PN40
- ANSI B16.5, 16.47 CL 150LB, 300LB, 600LB, 900LB / MSS SP44 CL 150LB, 300LB, 600LB, 900LB
- ISO 7005 PN10, PN16, PN25, PN40 / KS B 1511 / JIS B 2210 10K, 16K, 20K, 30K, 40K

Face to Face Dimensions

- Conform to API609, EN 558, ISO 5752 and ANSI B 16.34

Application

- Nuclear Power Plants
- Petrochemical Plants
- Petroleum Refinery
- Fossil Power Plants
- Desalination plants
- Food and beverage
- Paper industry
- Chemical processing
- Fire Safe line
- Exhaust Gas line & Steam line
- Cryogenic Services
- Ballast and bilge system
- Drinking water
- HAVC
- Thermo technical water treatment
- Mining industry

Double & Triple Offset Butterfly Valve



Standard Specification

Triple offset metal seated butterfly valves are widely used in plants and high pressure and high temperature piping system. The metal seat shall be consisted of laminated seat or solid seat.

Design : API 609, EN 593, ANSI B16.34

Pressure Class : Class 150, 300, 600, 900

Body Styles : Wafer, Lug, Double Flange, Butt Weld

Material

- Ductile Iron / Cast Steel / Stainless Steel
- Al-Bronze / Duplex / Monel / Inconel / Alloy Steel
- Other material on request

Pressure Test

- Shell test, Seat test : API 598
- Seat leakage rate : API 598, ISO 5208 Rate A
- ANSI B16.104(ANSI/FCI 70.2) Class VI

Fire safe

- BS 6755 Part 2
- API 6FA and API 607

Actuator

- Manual operation
- Hydraulic operation (driven by oil cylinder or oil motor)
- Pneumatic operation (driven by pneumatic cylinder)
- Electric motor operation

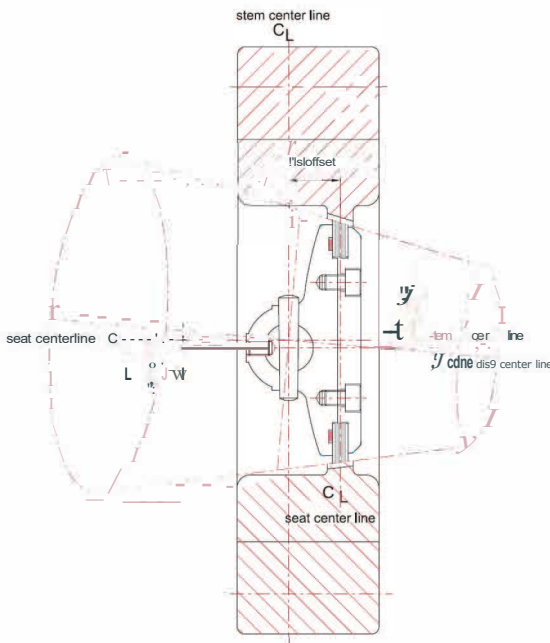

Design Features

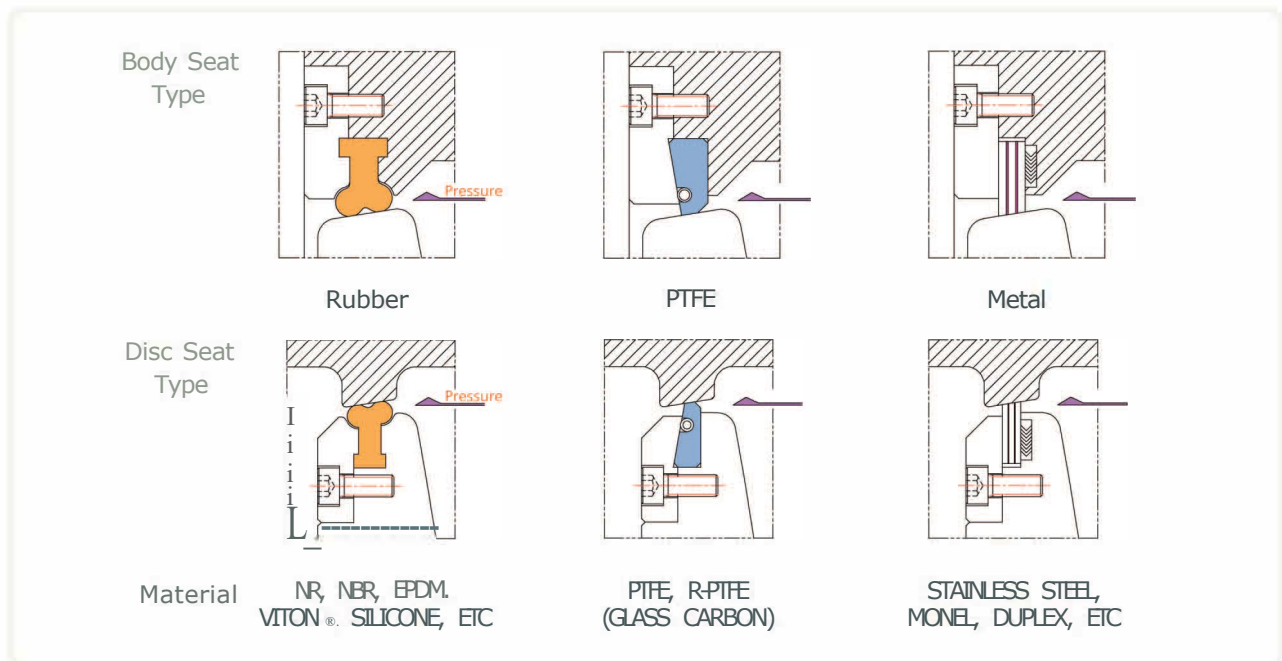



The New Concert For Metal Seated Valve

This product is of heavy load designed for high pressure flow application.

Excellent durability of seats area and low operating torque by non-rubbing characteristic with triple offset construction.

Achieved bubble tight service by the action of resilient metal seal and torque seating.

The seat rings both of body and disc are solid and real metal, can't be finished away as lamellar seat.

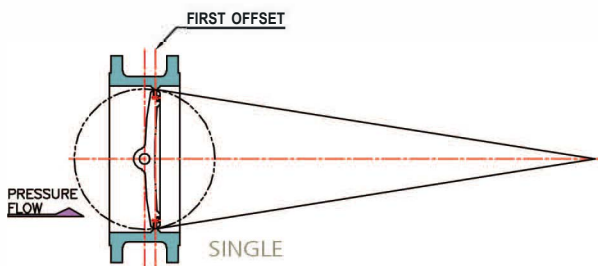

SINGLE OFFSET

The centre of rotation is moved back from the centreline of the valve disc.

The seat and seal are designed conically and on centre. This design relies on a frictional, interference seal and so is applicable only to soft seated valves.

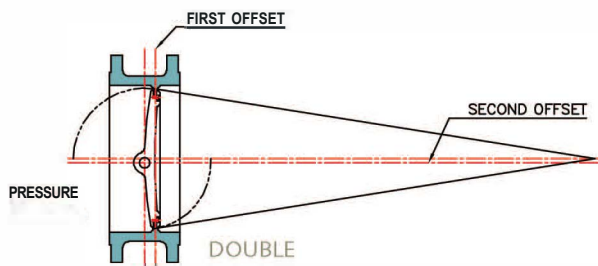

DOUBLE OFFSET

The centre of rotation is moved from the centerline of the valve body.

The seat and seal design remains conical and on centre. This design again relies on a frictional, interference seal, but the length of rotation over which this friction occurs is reduced, allowing a larger range of process resistant seat materials to be used.

However these materials must be relatively soft or highly elastic to prevent "jamming".

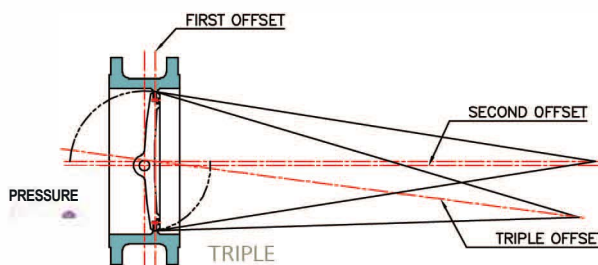

TRIPLE OFFSET

The centreline of the cone is rotated away from the valve centreline resulting in an ellipsoidal profile and providing the third offset. With this geometry, seat seal interference is completely eliminated ensuring long sealing life. The result is a torque seated, process pressure aided **FRICTIONLESS** seal.

The geometry allows the body seat to be used as the closed limit stop, aiding operator adjustment.

The Triple Offset design is ideally suited to metal seated valves providing bubble - tight performance on high temperature, high pressure and firesafe applications.

150LB Dimensions Table

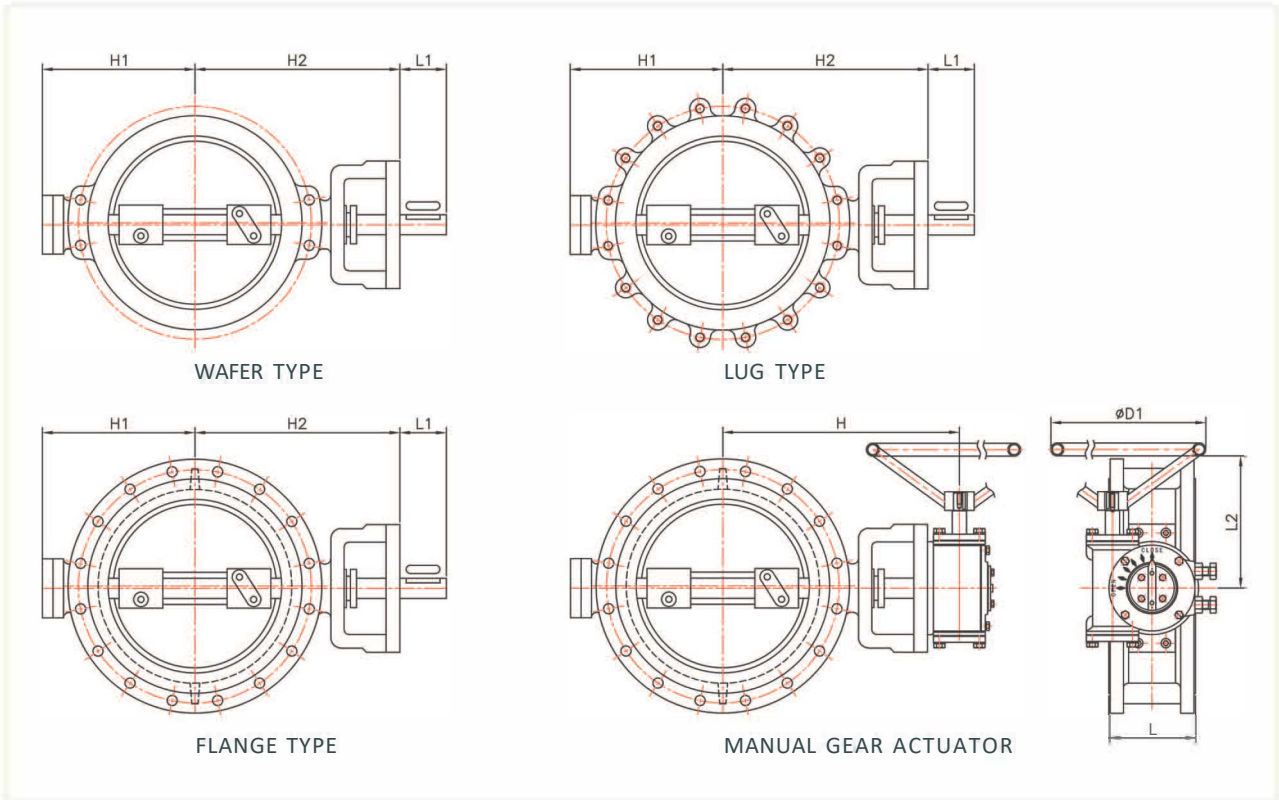

Dimensions

unit: mm

SIZE		H1 APPROX.	H2 APPROX.	H APPROX.	L1	L2	ØD1	L (F To F)			WEIGHT: Kg (APPROX.)		
mm	inch							WAFFER	LUG	FLANGE	WAFFER	LUG	FLANGE
50	2	105	145	185	40	144	200	43	43	108	-	-	-
65	2.5	120	160	200	40	144	200	46	46	112	-	-	-
80	3	125	165	205	40	144	200	48	48	114	-	-	-
100	4	150	200	240	40	144	200	54	54	127	-	-	-
150	6	180	245	290	40	177	250	57	57	140	20	22	48
200	8	195	260	305	45	177	250	64	64	152	45	47	89
250	10	225	285	340	45	228	300	71	71	165	57	61	112
300	12	265	335	390	55	257	400	81	81	178	85	91	161
350	14	290	365	420	65	257	400	92	92	190	133	142	228
400	16	340	435	500	70	314	500	102	102	216	186	199	303
450	18	360	450	515	70	314	500	114	114	220	213	229	364
500	20	395	500	565	80	348	560	127	127	229	334	364	499
600	24	465	570	645	90	413	630	154	154	267	455	492	699
700	28	570	685	760	100	413	630	165	165	292	718	777	860
750	30	600	695	770	110	413	630	165	165	318	864	934	1085
800	32	630	750	830	120	443	710	190	190	318	1090	1119	1241
900	36	690	820	900	120	443	710	200	200	330	1418	1553	1716
1000	40	720	835	945	140	552	800	216	216	410	1743	1943	2208
1050	42	750	860	970	140	552	800	251	251	410	2108	2343	2488
1200	48	845	1020	1135	160	602	900	276	276	470	3004	3284	3440

* FLANGE RATING : ANSI B 16.5 / ASME B16.47 SERIES "A"

FACE TO FACE DIMENSION : ISO 5752 / API 609 / EN558 / MAKER'S STANDARD / CUSTOMER'S REQUESTS

VALVE WEIGHT: EXCLUDING ACTUATOR

300LB Dimensions Table

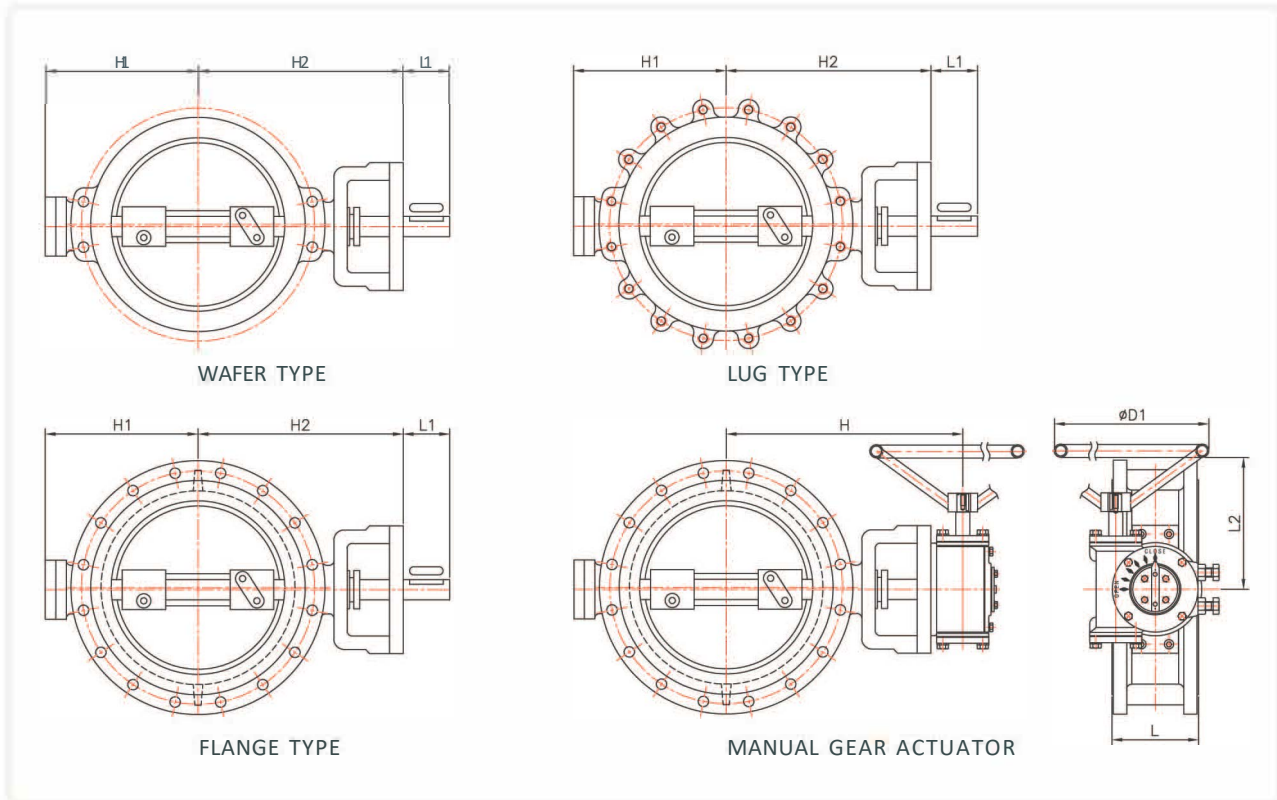

Dimensions

unit: mm

SIZE		H1 APPROX.	H2 APPROX.	H APPROX.	L1	L2	ØD1	L (F T o F)			WEIGHT : Kg (APPROX.)		
mm	inch							WAFER	LUG	FLANGE	WAFER	LUG	FLANGE
50	2	115	155	195	40	144	200	43	43	108	-	-	-
65	2.5	125	165	205	40	144	200	46	46	112	-	-	-
80	3	135	175	215	40	144	200	48	48	114	-	-	-
100	4	160	210	250	40	144	200	54	54	127	-	-	-
150	6	195	280	330	40	177	250	59	59	140	36	39	76
200	8	215	295	350	55	228	300	73	73	152	51	56	93
250	10	250	340	395	65	257	400	83	83	165	100	112	164
300	12	295	395	460	70	297	500	92	92	178	134	150	222
350	14	330	425	490	80	348	560	117	117	190	196	229	298
400	16	375	480	555	80	413	630	133	133	216	232	277	357
450	18	410	540	615	90	413	630	149	149	220	360	433	499
500	20	440	580	660	90	443	710	159	159	229	457	549	621
600	24	515	650	760	100	552	800	181	181	267	670	805	916
700	28	640	820	930	120	552	800	229	229	292	1193	1363	1417
750	30	690	850	965	130	552	900	230	230	318	1463	1658	1715
800	32	720	880	995	130	602	900	241	241	318	1661	1856	1957
900	36	780	960	1075	160	602	900	241	241	330	2281	2511	2590
1000	40	800	990	1115	180	741	1000	300	300	410	2214	2425	2585
1050	42	840	1050	1175	180	741	1000	300	300	410	2439	2649	2849
1200	48	950	1150	1300	200	781	1000	350	350	470	3384	3684	4106

* FLANGE RATING : ANSI B 16.5 / ASME B16.47 SERIES "A"

FACE TO FACE DIMENSION : ISO 5752 / API 609 / EN558 / MAKER'S STANDARD/ CUSTOMER'S REQUESTS

VALVE WEIGHT: EXCLUDING ACTUATOR

600LB Dimensions Table

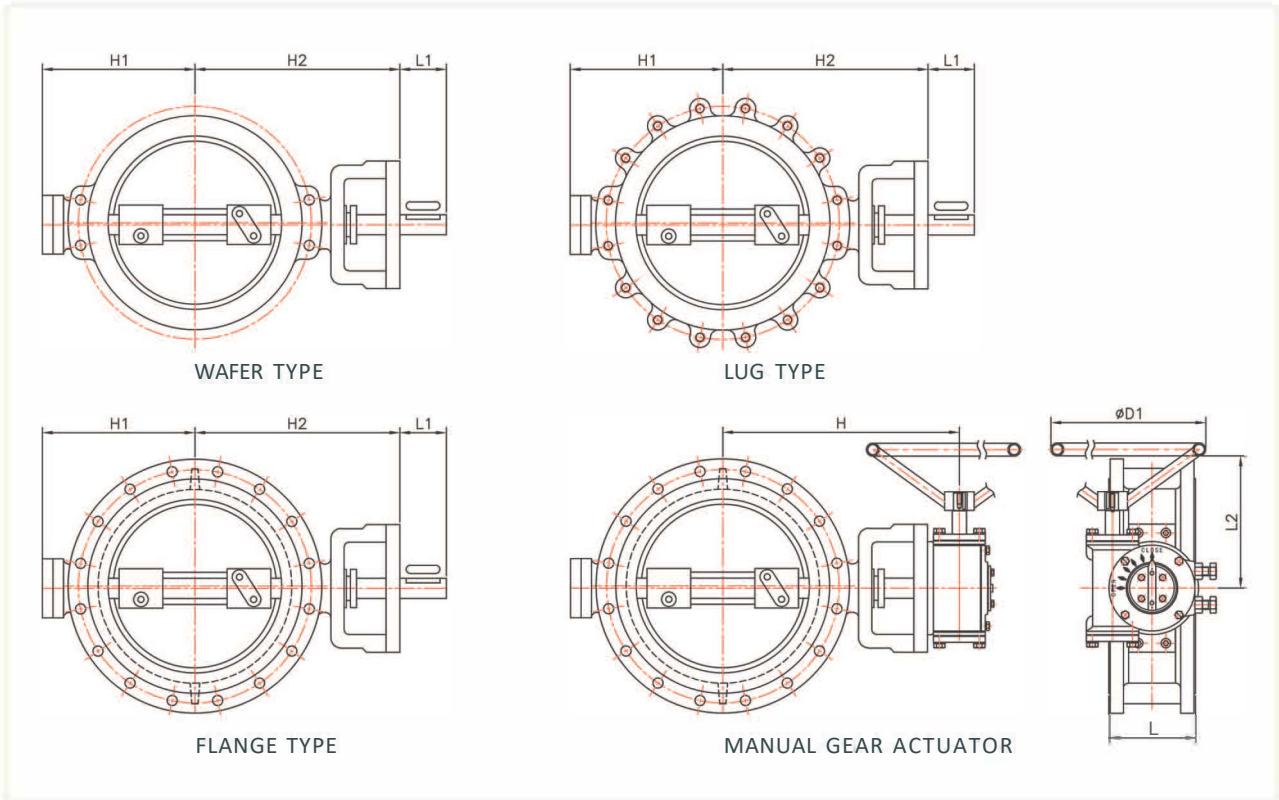

Dimensions

unit: mm

SIZE		H1 APPROX.	H2 APPROX.	H APPROX.	L1	L2	ØD1	L (F to F)			WEIGHT: Kg (APPROX.)		
mm	inch							WAFER	LUG	FLANGE	WAFER	LUG	FLANGE
80	3	154	210	265	45	230	400	54	54	180	15	16	43
100	4	150	200	255	45	230	400	64	64	190	28	30	69
150	6	238	310	365	80	230	400	78	78	210	65	72	135
200	8	248	325	380	80	230	400	102	102	230	92	102	162
250	10	316	400	465	80	279	450	117	117	250	134	187	268
300	12	349	455	520	110	312	560	140	140	270	224	259	369
350	14	374	470	535	110	312	560	155	155	290	285	329	464
400	16	474	585	675	130	371	630	178	178	310	455	520	632
450	18	476	625	715	130	371	630	200	200	330	555	635	739
500	20	504	670	760	130	425	710	216	216	350	694	804	879
600	24	555	750	840	180	425	710	232	232	390	1093	1243	1423
700	28												
750	30												
800	32												
900	36												
1000	40												
1050	42												
1200	48												

FOR THESE & SIZES, PLEASE CONTACT US

* FLANGE RATING : ANSI B 16.5 / ASME B16.47 SERIES "A"
 FACE TO FACE DIMENSION : ISO 5752 / API 609 / EN558 / MAKER'S STANDARD/ CUSTOMER'S REQUESTS
 VALVE WEIGHT: EXCLUDING ACTUATOR

900LB Dimensions Table

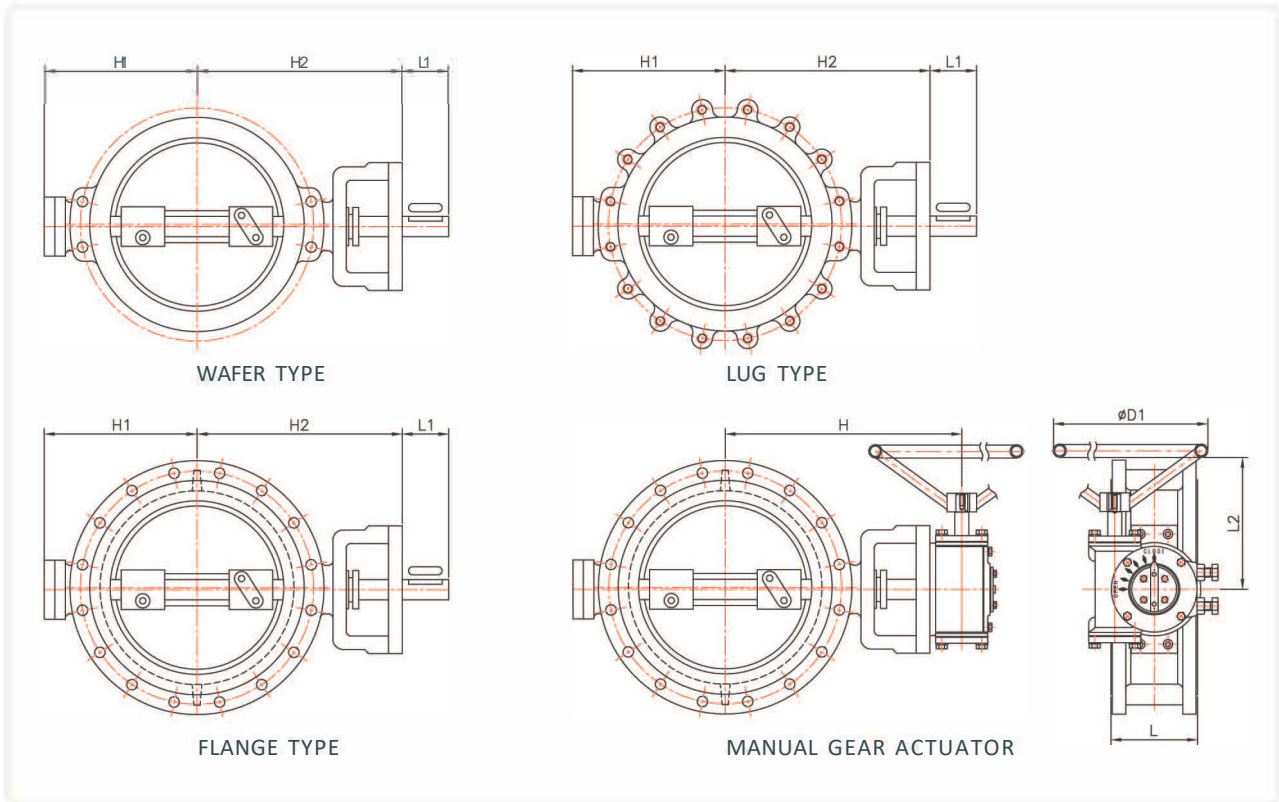

Dimensions

unit: mm

SIZE		H1 APPROX.	H2 APPROX.	H APPROX.	L1	L2	ØD1	L (F T o F)			WEIGHT : Kg (APPROX.)		
mm	inch							WAFER	LUG	FLANGE	WAFER	LUG	FLANGE
150	6	235	335	400	80	279	450	104	104	250	89	100	184
200	8	380	380	445	80	312	560	112	112	310	134	151	256
250	10	355	435	500	110	312	560	135	135	380	224	256	425
300	12	380	500	590	110	371	630	170	170	400	298	352	496
350	14	415	545	635	130	371	630	173	173	430	376	440	656
400	16	455	640	730	130	425	710	210	210	460	570	663	834
450	18	500	690	780	180	425	710	228	228	490	691	824	1044
500	20	550	710	830	180	513	800	250	250	530	905	1069	1273
600	24	656	820	950	200	513	800	275	275		1317	1704	2506
700	28												
750	30												
800	32												
900	36	FOR THESE & SIZES. PLEASE CONTACT US											
1000	40												
1050	42												
1200	48												

* FLANGE RATING : ANSI B 16.5 / ASME B16.47 SERIES "A"

FACE TO FACE DIMENSION : ISO 5752 / API 609 / EN558 / MAKER'S STANDARD/ CUSTOMER'S REQUESTS

VALVE WEIGHT: EXCLUDING ACTUATOR

Torque Required to Operate



Torque Table

unit: Nm

SIZE		10BAR		16BAR		22BAR	
mm	inch	UNSEATING	SEATING	UNSEATING	SEATING	UNSEATING	SEATING
50A	2	9	10	13	15	17	21
65A	2.5	15	18	21	26	30	35
80A	3	22	27	33	39	45	54
100A	4	38	45	55	65	75	90
150A	6	96	115	140	167	192	230
200A	8	219	263	318	381	437	524
250A	10	382	459	555	666	763	915
300A	12	609	731	884	1060	1214	1456
350A	14	908	1090	1318	1581	1809	2171
400A	16	1291	1549	1872	2246	2569	3083
450A	18	1898	2270	2752	3302	3776	4532
500A	20	2508	3009	3865	4638	5303	6364
600A	24	4087	4905	6250	7499	8570	10284
700A	28	6216	7460	9442	11330	12940	15527
750A	30	7870	9444	11378	13654	15588	18706
800A	32	9384	11261	13561	16273	18572	22287
900A	36	12972	15566	18725	22470	25629	30755
1000A	40	19367	23241	27953	33543	38255	45906
1050	42	21687	26024	31279	37535	42790	51348
1200	48	30388	36466	43748	52498	59780	71736

The operating speed of the actuator must be considered in order to avoid water hammer when the valve is closed in junction with Liquid.

The factors affect the torque required to operate Butterfly valves.

- Valve Diameter
- Shaft Diameter
- Bearing Friction Coefficient
- Type of Seat Material
- Shutoff Pressure
- Velocity
- Shape of Disc
- System Head Characteristics
- Piping Arrangement

Actuator torque can be calculated using the following formulas.

$T_a = T_b + T_s + T_h = 1.2T_b \pm T_d$	Ta : The required actuator torque(lb-ft)	d : Diameter of Shaft(inch)
$T_s = C_s D^2$	Ts : Seating or unseating torque(lb-ft)	P : Pressure drop across valve(psi)
$T_b = 4.17D^2 dfP$	Td : Dynamic torque(lb-ft)	Cs : Coefficient of Seating/unseating torque
$T_d = C_t D^3 P$	Th : Hydrostatic torque (lb-ft)	Ct : Coefficient of dynamic torque
$T_h = 3.06D^4$	Q : Flow (cubic for per second)	Cf : Coefficient of flow
$V = C_f \sqrt{P} = \frac{Q}{0.785D^2}$	V : Velocity(feet per second)	f : Bearing friction coefficient
	D : Diameter of valve (feet)	



Basic Formulas for obtaining Cv-Value



Basic Formulas for obtaining Cv-Value

Cv is in imperial units, the water flow in U.S. gallons per minute which passes through the valve giving a pressure drop of 1 PSI at a temperature of 68 °F.

In metric units the same coefficient is called Kv and correspond to the flow rate in m³/h passing through the valve giving a pressure drop of 1bar at a temperature of 20 °C

The approximate corresponding formulas are:

Where :

- Q = valve flow rate in gpm (USGPM)
- ΔP = pounds per square inch (psi) pressure drop through the valve
- 62.4 = conversion factor for fluids computed in relation to water
- D = is pounds per cu.ft (pct) fluid density

$$Q = Cv \cdot \sqrt{(\Delta P \cdot 62.4/D)}$$

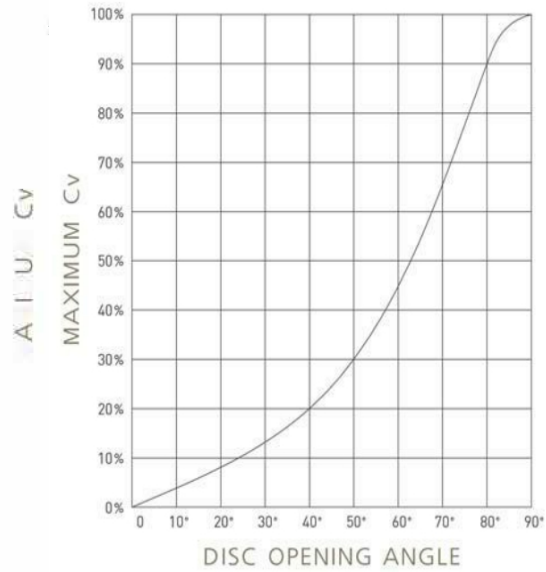

Where :

- Q = valve flow rate in m³/h
- ΔP = pressure drop through the valve in bar
- 1000 = conversion factor for fluids computed in relation to water
- D = kg /m³ fluid density

$$Q = Kv \cdot \sqrt{(\Delta P \cdot 1000/D)}$$

The relation between Cv and Kv, expressed in the above mentioned unit of measure is as follows :
Cv = 1.16Kv

Flow coefficient

SIZE		DISC OPENING										
mm	inch	5°	10°	20°	30°	40°	50°	60°	70°	80°	85°	90°
50	2	3	6	12	18	27	45	72	116	179	204	214
65	2.5	5	10	20	30	46	75	122	197	302	345	362
80	3	7	15	30	45	70	114	184	298	458	522	548
100	4	12	23	46	70	109	178	288	466	715	815	856
150	6	26	52	104	158	246	401	647	1048	1610	1835	1927
200	8	46	93	186	280	437	713	1151	1863	2862	3262	3426
250	10	72	145	290	438	682	1114	1798	2911	4472	5096	5353
300	12	104	208	418	630	983	1604	2589	4192	6439	7339	7708
350	14	142	283	569	858	1338	2183	3523	5705	8764	9989	10491
400	16	185	370	743	1121	1747	2852	4602	7452	11447	13047	13703
450	18	234	468	940	1418	2211	3609	5824	9431	14488	16513	17343
500	20	289	578	1161	1751	2730	4456	7191	11644	17886	20386	21411
600	24	416	833	1672	2522	3931	6416	10355	16767	25756	29356	30832
700	28	566	1133	2275	3432	5351	8733	14094	22821	35057	39956	41965
750	30	650	1301	2612	3940	6142	10025	16179	26198	40244	45868	48175
800	32	739	1480	2972	4483	6989	11406	18408	29807	45788	52188	54812
900	36	936	1873	3761	5674	8845	14436	23298	37725	57951	66050	69371
1000	40	1155	2313	4643	7005	10920	17822	28963	46574	71544	81544	85644
1050	42	1274	2550	5119	7723	12039	19649	31711	51348	78877	89902	94422
1200	48	1664	3331	6686	10087	15725	25664	41419	67067	103024	117423	123327



Recommended Standard and Specifications

Butterfly valve manufactured according to most severe quality control standards

ANSI	816.5 816.34	Steel pipeline flanges Steel valves
MSS	SP-6 SP-25 SP-44 SP-55 SP-61 SP-67 narrow(C1-D1)	Standard finishes for pipe flanges Standard marking system for valves Steel pipeline flanges Quality standard for steel castings Pressure testing of steel valves Butterfly valves
API	598 609	Valve inspections and testing Butterfly valves Wafer and Lug type (face to face on valve)
ISO	7005 5208 5209 5211/1 5752 Tab.5 (20series)	Metallic flanges Industrial valves - pressure testing of valves General purpose industrial valves - marking Part-turn valve actuator attachment -top flange dimensions Face-to-face and centre-to-face dimensions
EN	558 593 1092	Face-to-face and centre-to-face dimensions of metal valves for use in flanged pipe systems. Industrial valves - Metallic butterfly valves. Circular flanges for pipes, valves, fittings and accessories, PN designated.
AWWA	C504	Rubber Seated Butterfly valves
JIS	82002 82003	Face to face dimensions Valve Test

Inspection and testing in according to ISO5208, MSS SP61, AWWA C504, JIS B2003, API 598, and EN 593.

The Body Test is performed at 1.5 times the nominal pressure while the Seat Test at 1.1 times the nominal pressure, using for both emulsified water at room temperature. While testing, no leakage shall be noticed from the stems, as for the Body Test, not from upstream to downstream, as for the Seat Test.

For the Pneumatic Test with disc closed the butterfly is covered with water and soap on that side where the visual control if the seal is performed, in order to show up a possible leak. Our valves are tested 100% before being delivered.

Pressure/ Temperature Rating

Temperature		Class 150				Class 300				Class 600				Class 900			
		Carbon Steel		Stainless Steel		Carbon Steel		Stainless Steel		Carbon Steel		Stainless Steel		Carbon Steel		Stainless Steel	
°F	°C	barg	psig	barg	psig	barg	psig	barg	psig	barg	psig	barg	psig	barg	psig	barg	psig
-200 - 100	-29 - 38	19.6	285	18.9	275	51	740	49.6	720	102	1480	99.3	1440	153.1	2220	148.9	2160
200	93	17.9	260	16.5	240	46.5	675	42.7	620	93.1	1350	85.5	1240	139.6	2025	128.2	1860
300	149	15.8	230	14.8	215	45.1	655	38.6	560	90.6	1315	77.2	1120	135.8	1970	115.8	1680
400	204	13.7	200	13.4	195	43.7	635	35.5	515	87.5	1270	71	1030	131	1900	106.2	1540
500	260	11.7	170	11.7	170	41.3	600	33.1	480	82.7	1200	65.8	955	123.7	1795	98.9	1435
600	316	9.6	140	9.6	140	37.9	550	31	450	75.5	1095	62.4	905	113.1	1640	93.4	1355
650	343	8.6	125	8.6	125	36.8	535	30.6	445	74.1	1075	61.3	890	111	1610	91.7	1330
700	371	7.5	110	7.5	110	36.8	535	29.6	430	73.3	1065	59.6	865	110.3	1600	89.3	1295
750	399	6.5	95	6.5	95	34.8	505	29.3	425	69.6	1010	58.2	845	104.1	1510	87.5	1270
800	427	5.5	80	5.5	80	28.2	410	28.6	415	56.8	825	57.2	830	85.1	1235	85.8	1245
850	454	4.4	65	4.4	65	18.6	270	27.9	405	36.8	535	55.8	810	55.5	805	83.7	1215
900	482	3.4	50	3.4	50	11.7	170	27.2	395	23.7	345	54.4	790	35.5	515	81.3	1180
950	510	2.4	35	2.4	35	7.2	105	26.5	385	14.1	205	53.4	775	21.3	310	80	1160
1000	538	1.3	20	1.3	20	3.4	50	25.1	365	7.2	105	50	725	10.6	155	75.1	1090
1050	566	-	-	1.3111	20111	-	-	24.8	360	-	-	49.6	720	-	-	74.4	1080
1100	593	-	-	1.3111]	20111	-	-	22.4	325	-	-	44.4	645	-	-	66.5	965
1150	621	-	-	1.3111	20111	-	-	18.9	275	-	-	37.9	550	-	-	56.8	825
1200	649	-	-	1.3111	20(11	-	-	14.1	205	-	-	28.2	410	-	-	42.7	620

* WCB permissible but not recommended for prolonged use above 426 °c (800 ° F)
For welding end valves only, flanged end ratings terminates at 538 °c (1000 ° F)



General

- Valve can be installed in the pipeline in any position.
- Before installing valves, the pipeline must be cleaned from dirt and welding residues. Otherwise seat may be damaged.
- The pipeline must be free from tension and electric current.
- When handling valves, be careful to avoid contact with or impact by other equipment, vault walls or trench walls.
- Check carefully to see if valve seat/disc surface, as well as mating face, is all clean.
- Tighten again, if any, all bolts loosened during transport and/or handling.
- Open and close valves to check for proper operation.
- If possible, install valves in the direction of arrow mark on it for easier access and maintenance.
- Do not use valve as a substitute for jack when putting pipes in alignment.
- The span of pipeline having connection between valve and pipe should be free from such excessive loading as may cause serious bending.

Installation on the existing pipeline

- Verify the distance between two flanges to be equal to face to face valve dimension.
- In order to facilitate installation of the valve, allow a sufficient room with adequate tools in between two flanges.
- Insert at least two flange-bolts through the two bottom pipe flange holes to rest valves on during installation.
- Close valve disc partially so that disc edge is at least 10 mm within the body.
- Insert valve in between two flanges. Flange gaskets should be positioned, aligned with valve bore.
- Valve will be held by the two flange-bolts previously fitted in the lower part of flanges.
- Insert the remaining flange-bolts aligning the valve with the flanges and tightening flange-bolts manually.
- Maintain the valve aligned, remove gradually flange spreaders and tighten bolts partially.
- Control open and close operation of valve to be easy and smooth.
- Open the valve completely and cross tighten the bolts to adequate torque.

Installation of lug type butterfly valves has the same procedure with wafer type except using cap screws instead of bolts and nuts.

Installation of the new pipeline

- Shut partially valve disc until disc profile is at least 10 mm within the body.
- Align the two flanges with the valves body. Flange gaskets should be positioned, aligned with valve bore.
- Span the body with some flange-bolts and tighten the bolts partially.
- Finish tightening by uniform cross bolting. Use the flange-valve-flange unit for pipe centering.
- Tack-weld the flanges to the pipe.
- Remove the bolts and the valve from the flanges. Just perform tack-welding only when the valve is inserted, high heat temperature can damage valve seat.
- Weld flange to the pipe and wait until completely cooled down.
- Install the valve by applying the same instruction procedure as the installation instruction on the existing pipeline.

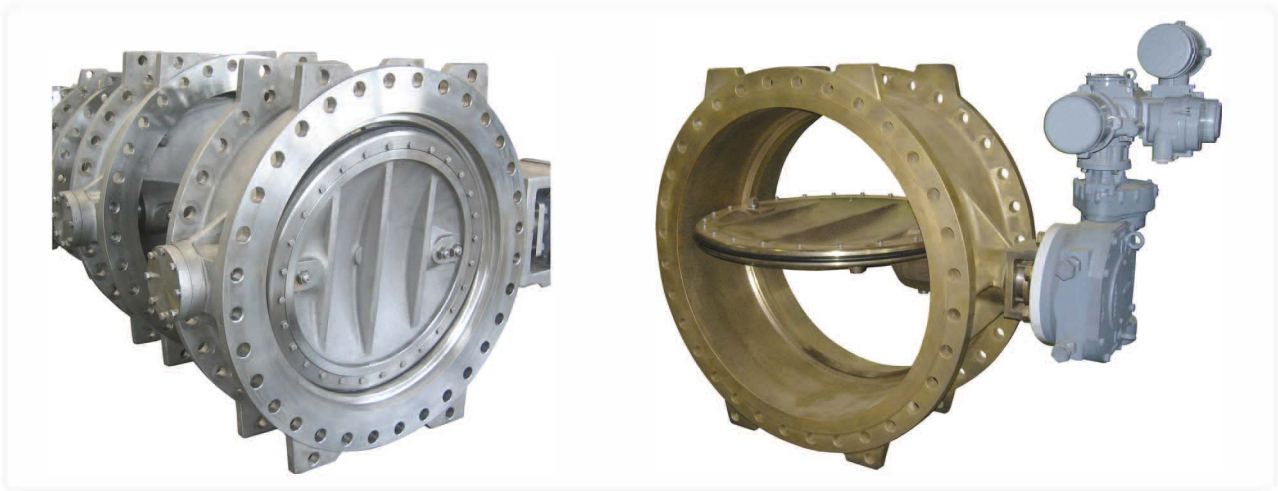
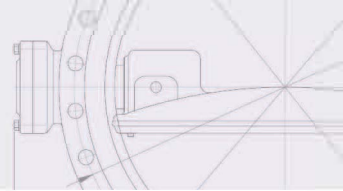

100% Bi-directional tight shut off at full rated pressure

Valve Type

- WAFER - SRS713W Eccentric Butterfly valves
- FLANGE - SRS713 Eccentric Butterfly valves

Standard Compliance

- The face to face dimension shall be in accordance with EN 593, AWWA, C504 or other STANDARD are available upon request.
- Rubber lining on body & disc of valve is available to manufacture according to customer's request.

Production Range

- Size : DN 50 to DN 4000 (4 inch - 160 inch)
- Working Pressure : upto 25 bar for DN 80 - DN 600
upto 16 bar for DN 650 - DN 1000
upto 10 bar for DN 1200 - DN 4000
- Working Temperature : -20° C - +160° C

Connection Flange

- EN 1092 PN10, PN16 / ANSI B 16.1 CL.125LB & B16.5 CL.150LB
- MSS SP44 CL.150LB
- AWWA C207 Class D & E
- ISO 7005 PN10 PN16 / KS B 1511 / JIS B 2210 10K, 16K and 20K

Face to Face Dimensions

- Conform to EN 558, ISO 5752, AWWA C504

Application

- Water Works
- Sewage Plant
- Desalination Plant
- Air Conditioning
- Irrigation
- Power Plant
- Heating and Ventilation
- Chemical Industry etc.
- Shipbuilding Industry
- Gas Plant

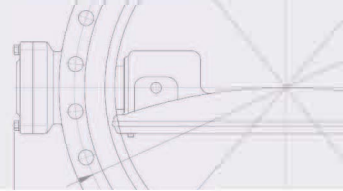

Schema of Eccentric type

- Basic Design : AWWA C504 or EN 593
- Employs an advanced lining procedure, this valve is designed and manufactured in accordance with AWWA C504 or EN593 for use in corrosive service, that is, circulating water service, condenser partition and condenser isolation for the Electric Utilities, Seawater Applications, Desalination plants, Chemical Processes, and so on. Operation is easy and suited for heavy duty services.
- The valve shall be capable of bi-directional sealing
- Valves are constructed with rugged shaft and bearing with self lubrication, and operate with low torque.
- Wide variety of body materials is available.

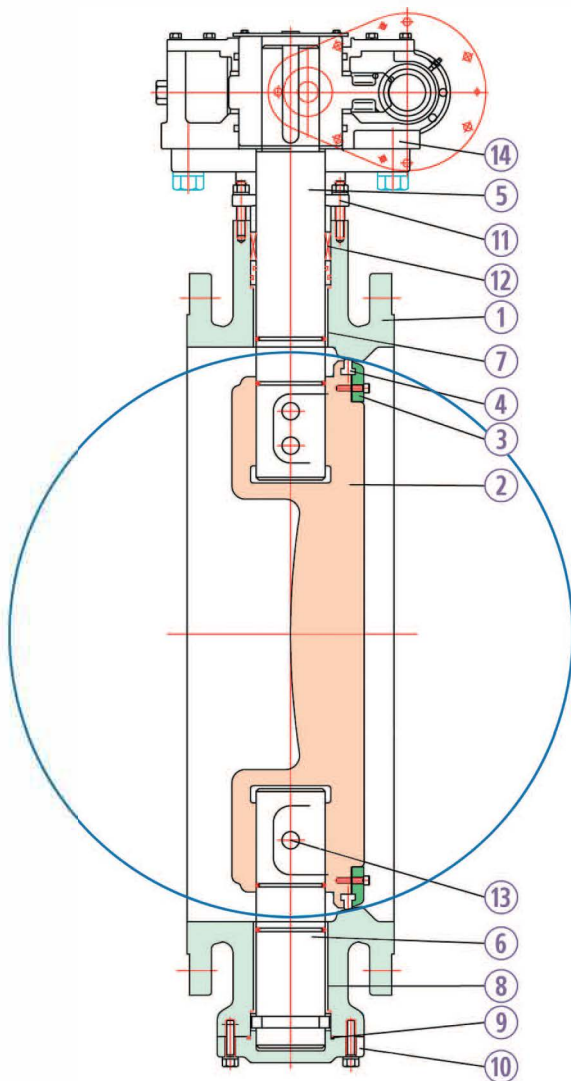

P. No.	PART NAME	MATERIAL
1	BODY	Ductile iron / Cast steel Stainless steel / Ni-AL Bronze
2	DISC	Ductile iron / Cast steel Stainless steel / Ni-AL Bronze
3	RETAINER	Cast steel Stainless steel / Ni-AL Bronze
4	SEAT	NBR. EPDM. VITON
5	UPPER-STEM	Stainless steel (304, 316, 316L, 630(17-4PH). Super duplex. monel)
6	LOWER-STEM	Stainless steel (304, 316, 316L, 630(17-4PH). Super duplex. monel)
7	BEARING	Oilless Bearing
8	BEARING	Oilless Bearing
9	GASKET	Non ASBESTOS / O-RING
10	BOTTOM COVER	Ductile iron / Cast steel Stainless steel / Ni-AL Bronze
11	PARKING GLAND	Ductile iron / Cast steel Stainless steel / Ni-AL Bronze
12	PARKING	PTFE, GRAPHITE, Rubber
13	DISKPIN	Stainless steel
14	GEARBOX	ASS'Y

SRS 713W - WAFER TYPE Waterworks Butterfly Valve

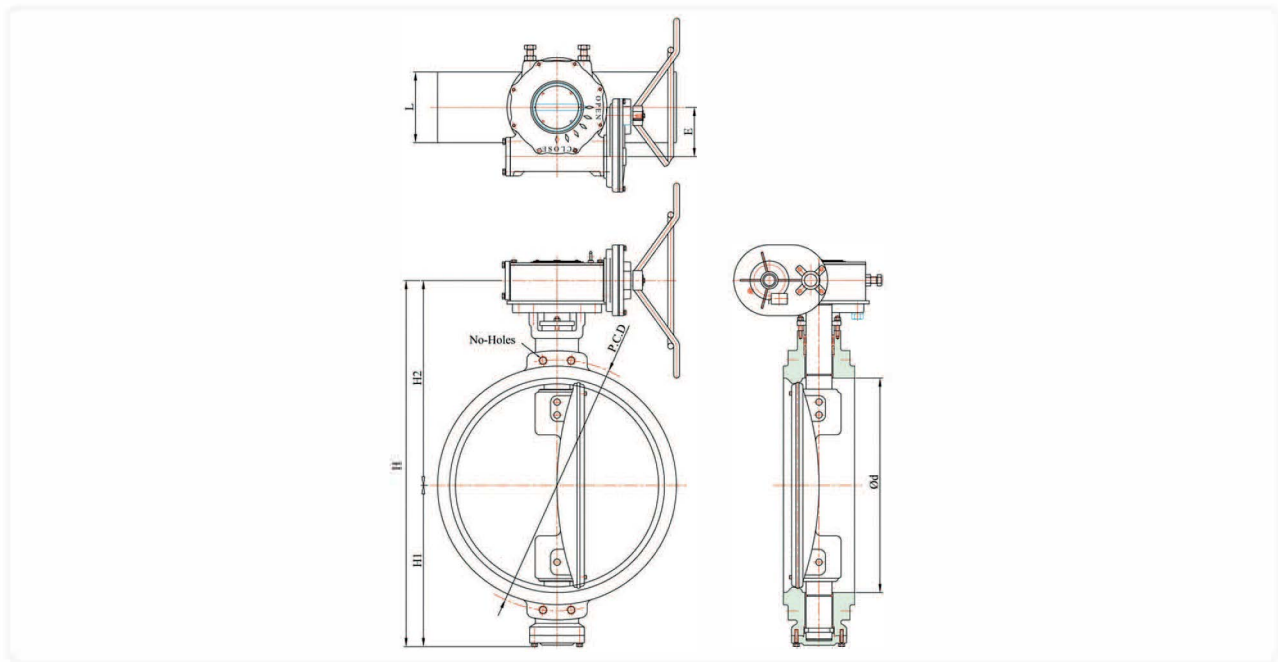
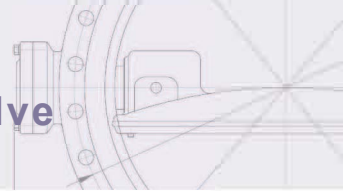

Dimensions

unit: mm

SIZE		ød	L	FLANGE 150LB			H	H1	H2	E	WEIGHT APPROX kg
inch	mm			OD	PCD	NO-HOLE					
2	50	50	43	152	120.5	4-19	325	115	210	66	7.2
3	80	80	64	190	152.5	4-19	395	145	250	66	10
4	100	100	64	229	190.5	8-19	427	162	265	66	39
6	150	150	76	279	241.5	8-22	492	192	300	66	46
8	200	200	89	343	298.5	8-22	526	209	317	80	50
10	250	250	114	406	362	12-25	619	254	365	80	72
12	300	300	114	483	432	12-25	692	278	414	120	81
14	350	350	127	533	476	12-29	789	324	465	120	102
16	400	400	140	597	539.5	16-29	844	349	495	120	128
18	450	450	152	635	578	16-32	942	402	540	120	170
20	500	500	152	698	635	20-32	1035	427	608	120	198
22	550	550	170	749	692.2	20-35	1090	470	620	120	22
24	600	600	178	813	749.5	20-35	1165	502	663	203	308
28	700	700	229	927	863.5	28-35	1240	537	703	203	380
30	750	750	230	984.5	914.5	28-35	1325	575	750	203	570
32	800	800	241	1060.5	978	28-41	1370	605	765	203	730
36	900	900	300	1168	1086	32-41	1512	682	830	203	880
40	1000	1000	300	1289	1200	36-41	1710	752	958	203	1040
44	1100	1100	350	1403	1314	40-41	1800	800	1000	203	1195
48	1200	1200	350	1511	1422	44-41	1945	865	1080	203	1410
52	1300	1300	350	1625	1537	44-47	2060	920	1140	270	1780
54	1350	1350	350	1683	1594	44-48	2140	940	1200	270	2100
56	1400	1400	390	1746	1651	48-48	2217	956	1261	270	2400
60	1500	1500	390	1854	1759	52-48	2360	1050	1310	270	2800
64	1600	1600	440	-	-	-	2500	1120	1380	270	3500
66	1650	1650	440	2032	1930.4	52-48	2630	1180	1450	270	3900
72	1800	1800	490	2197	2095.5	60-48	2740	1230	1510	550	4450
80	2000	2000	540	2325	2230	48-48	2890	1290	1600	550	5830
84	2100	2100	540	2534	2425.7	64-57	2950	1330	1620	550	6560
96	2400	2400	650	2876.5	2756	68-70	4155	1980	2175	550	10600
112	2800	2800	650				4650	2145	2495	700	18500
120	3000	3000	800				5600	2695	2985	700	23800
140	3500	3500	850				6600	3145	3440	700	28800
160	4000	4000	900				7450	3590	3800	700	34900

NOTE
For 2800A and above,
it is available upon request

* Specification and design are subject to change without notice

SRS 713 - FLANGE TYPE Waterworks Butterfly Valve

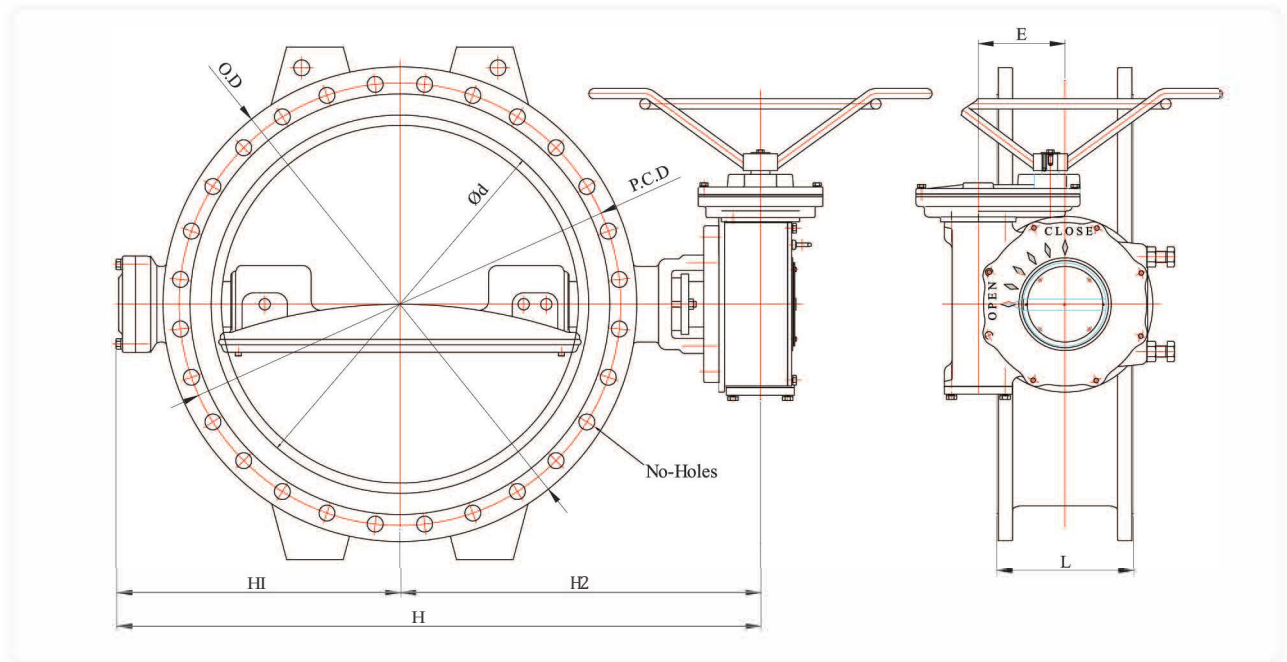

Dimensions

unit: mm

SIZE		Ød	L	FLANGE 150LB			H	HI	H2	E	WEIGHT IAPPROX. kg
inch	mm			OD	PCD	NO-HOLE					
2	50	50	43	152	120.5	4-19	325	115	210	66	9.5
3	80	80	64	190	152.5	4-19	395	145	250	66	15
4	100	100	127	229	190.5	8-19	427	162	265	66	52
6	150	150	127	279	241.5	8-22	492	192	300	66	61
8	200	200	153	343	298.5	8-22	526	209	317	80	68
10	250	250	203	406	362	12-25	619	254	365	80	99
12	300	300	203	483	432	12-25	692	278	414	120	110
14	350	350	203	533	476	12-29	789	324	465	120	134
16	400	400	203	597	539.5	16-29	844	349	495	120	170
18	450	450	203	635	578	16-32	942	402	540	120	230
20	500	500	203	698	635	20-32	1035	427	608	120	266
22	550	550	203	749	692.2	20-35	1090	470	620	120	298
24	600	600	203	813	749.5	20-35	1165	502	663	203	410
28	700	700	203	927	863.5	28-35	1240	537	703	203	510
30	750	750	305	984.5	914.5	28-35	1325	575	750	203	758
32	800	800	305	1060.5	978	28-41	1370	605	765	203	980
36	900	900	305	1168	1086	32-41	1512	682	830	203	1180
40	1000	1000	305	1289	1200	36-41	1710	752	958	203	1395
44	1100	1100	305	1403	1314	40-41	1800	800	1000	203	1588
48	1200	1200	381	1511	1422	44-41	1945	865	1080	203	1890
52	1300	1300	381	1625	1537	44-47	2060	920	1140	270	2385
54	1350	1350	381	1683	1594	44-48	2140	940	1200	270	2800
56	1400	1400	381	1746	1651	48-48	2217	956	1261	270	3250
60	1500	1500	457	1854	1759	52-48	2360	1050	1310	270	3705
64	1600	1600	457	-	-	-	2500	1120	1380	270	4675
66	1650	1650	457	2032	1930.4	52-48	2630	1180	1450	270	5200
72	1800	1800	457	2197	2095.5	60-48	2740	1230	1510	550	5960
80	2000	2000	457	2325	2230	48-48	2890	1290	1600	550	7780
84	2100	2100	457	2534	2425.7	64-57	2950	1330	1620	550	8750
96	2400	2400	650	2876.5	2756	68-70	4155	1980	2175	550	14650
112	2800	2800	650	-	-	-	4650	2145	2495	700	25800
120	3000	3000	800	-	-	-	5600	2695	2985	700	32000
140	3500	3500	850	-	-	-	6600	3145	3440	700	39800
160	4000	4000	900	-	-	-	7450	3590	3800	700	47680

NOTE
For 2800A and above,
it is available upon request

* Specification and design are subject to change without notice

Torque Required to Operate

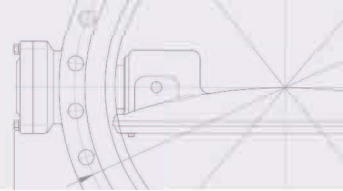

Torque Table

unit: kg.m/Nm/in-lb

SIZE		Working Pressure (bar)											
		3 bar			5 bar			10 bar			16 bar		
mm	inch	kg-m	Nm	in-lb	kg-m	Nm	in-lb	kg-m	Nm	in-lb	kg-m	Nm	in-lb
100	4	1	9.8	86.74	1.5	14.7	130.11	3.5	34.3	303.58	5.2	50.96	451.03
125	5	2.2	21.56	190.82	3	29.4	260.21	7	68.6	607.16	8.4	82.32	728.59
150	6	3	29.4	260.21	4	39.2	346.95	10.5	102.9	910.74	14	137.2	1214.32
200	8	5.5	53.9	477.06	9	88.2	780.64	20	196	1734.75	28	274.4	2428.65
250	10	13	127.4	1127.59	18	176.4	1561.27	48	470.4	4163.39	65	637	5637.93
300	12	18.5	181.3	1604.64	32	313.6	2775.6	65	637	5637.93	88	862.4	7632.89
350	14	27.5	269.5	2385.28	45	441	3903.18	88	862.4	7632.89	135	1323	11709.54
400	16	44	431.2	3816.44	80	784	6938.99	115	1127	9974.8	182	1783.6	15786.2
450	18	62	607.6	5377.72	100	980	8673.74	165	1617	14311.66	232	2273.6	20123.07
500	20	75	735	6505.3	132	1293.6	11449.33	202	1979.6	17520.94	305	2989	26454.89
550	22	130	1274	11275.86	182	1783.6	15786.2	240	2352	20816.96	408	3998.4	35388.84
600	24	142	1391.6	12316.7	220	2156	19082.22	305	2989	26454.89	495	4851	42934.99
650	26	160	1568	13877.98	285	2793	24720.14	408	3998.4	35388.84	602	5899.6	52215.88
700	28	225	2205	19515.9	340	3332	29490.7	515	5047	44669.74	805	7889	69823.57
750	30	260	2548	22551.7	415	4067	35996	601	5889.8	52129.15	910	8918	78930.99
800	32	305	2989	26454.89	470	4606	40766.55	695	6811	60282.46	1005	9849	87171.04
850	34	348	3410.4	30184.6	530	5194	45970.8	875	8575	75895.18	1310	12838	113625.93
900	36	388	3802.4	33654.09	635	6223	55078.22	980	9604	85002.6	1450	14210	125769.16
1000	40	420	4116	36429.69	690	6762	59848.77	1195	11711	103651.13	1625	15925	140948.19
1200	48	1113.2	10909.36	96556.02	1391.5	13636.7	120695.02	2112	20697.6	183189.28	2917.2	28588.56	253030.2
1350	54	1305.25	12791.45	113213.93	1652	16189.6	143290.1	2428.8	23802.24	210667.68	2918.52	28601.5	253144.69
1800	72	2265.5	22201.9	196503.47	2666.8	26134.64	231311.16	3336	32692.8	289355.8	5033.16	49324.97	436562.96
3000	120	12075	118335	1047353.5	14593.06	143011.99	1265763.4	25020	245196	2170168.5	37791.6	370357.68	3277943.2
4000	160	45770	448546	3969968.5	48970	479906	4247528	58620	574476	5084543.5	88836	870592.8	7705399.2

The operating speed of the actuator must be considered in order to avoid water hammer when the valve is closed in junction with Liquid.

The factors affect the torque required to operate Butterfly valves.

- Valve Diameter
- Shaft Diameter
- Bearing Friction Coefficient
- Type of Seat Material
- Shutoff Pressure
- Velocity
- Shape of Disc
- System Head Characteristics
- Piping Arrangement

Actuator torque can be calculated using the following formulas.

$T_a = T_b + T_s + T_h = 1.2T_b + T_d$ $T_s = C_s D^2$ $T_b = 4.17 D^2 d f P$ $T_d = C_t D^3 P$ $T_h = 3.06 D^4$ $V = C_f \sqrt{P} = \frac{Q}{0.785 D^2}$	<p>T_a : The required actuator torque(lb-ft)</p> <p>T_s : Seating or unseating torque(lb-ft)</p> <p>T_d : Dynamic torque(lb-ft)</p> <p>T_h : Hydrostatic torque (lb-ft)</p> <p>Q : Flow(cubic for per second)</p> <p>V : Velocity(feet per second)</p> <p>D : Diameter of valve(feet)</p>	<p>d : Diameter of Shaft(inch)</p> <p>P : Pressure drop across valve(psi)</p> <p>C_s : Coefficient of Seating/unseating torque</p> <p>C_t : Coefficient of dynamic torque</p> <p>C_f : Coefficient of flow</p> <p>f : Bearing friction coefficient</p>
---	---	--

Basic Formulas for obtaining Cv-Value

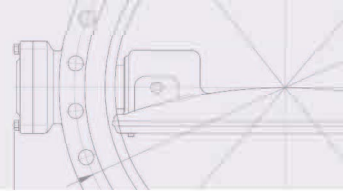

Hydro Test Specifications

Series	ISO Series	AWWA Series
"Hydrostatic Shell test"	1.5 x Maximum service pressure	2.0 x Maximum service pressure
"Hydrostatic Seat test"	1.1 x Working service pressure	Working service pressure

Basic Formulas for obtaining Cv-Value

Cv is in imperial units, the water flow in U.S. gallons per minute which passes through the valve giving a pressure drop of 1 PSI at a temperature of 68 °F

In metric units the same coefficient is called Kv and correspond to the flow rate in m³/h passing through the valve giving a pressure drop of 1bar at a temperature of 20 °C

The approximate corresponding formulas are :

$$Q = C_v \cdot \sqrt{(\Delta P \cdot 62.4/D)}$$

$$Q = K_v \cdot \sqrt{(\Delta P \cdot 1000/D)}$$

Where:

Q = valve flow rate in gpm (USGPM)

ΔP = pounds per square inch (psi)
pressure drop through the valve

62.4 = conversion factor for fluids
computed in relation to water

D = pounds per cu.ft (pcf) fluid density

Where :

Q = valve flow rate in m³/h

ΔP = pressure drop through the valve in bar

1000 = conversion factor for fluids

D = computed in relation to water

D = kg /m³ fluid density

The relation between Cv and Kv, expressed in the above mentioned unit of measure is as follows :
Cv = 1.16Kv

Flow coefficient

SIZE		DISC OPENING																	
		10°		20°		30°		40°		50°		60°		70°		80°		90°	
inch	mm	Kv	Cv	Kv	Cv	Kv	Cv	Kv	Cv	Kv	Cv	Kv	Cv	Kv	Cv	Kv	Cv	Kv	Cv
2	50	1.7	2	9.5	11	12.9	15	27.6	32	41.4	48	50.9	59	56	65	61.2	71	71.6	83
2.5	65	3.4	4	11.2	13	18.1	21	29.3	34	45.7	53	60	80	95.7	111	120.7	140	131.9	153
3	80	6	7	15.5	18	30.2	35	50	58	77.6	90	118.1	137	155.2	180	203.4	236	225	261
4	100	12	14	30	35	54	63	95	110	145	168	191	222	254	295	341	395	397	460
5	125	19	22	50	58	91	105	151	175	227	263	345	400	461	535	569	660	647	750
6	150	28	32	95	110	155	180	241	280	353	410	500	580	690	800	875	1015	948	1100
8	200	50	58	138	160	250	290	379	440	603	700	858	995	1207	1400	1595	1850	1810	2100
10	250	73	85	198	230	379	440	578	670	905	1050	1293	1500	1879	2180	2457	2850	2802	3250
12	300	103	120	276	320	500	580	819	950	1293	1500	1897	2200	2629	3050	3466	4020	3879	4500
14	350	161	187	414	480	845	980	1155	1340	1983	2300	2543	2950	3724	4320	4397	5100	5216	6050
16	400	207	240	534	620	1138	1320	1569	1820	2491	2890	3586	4160	5198	6030	6991	8110	8190	9500
18	450	260	302	690	800	1345	1560	2060	2390	3259	3780	4603	5340	6681	7750	8603	9980	10328	11980
20	500	328	380	849	985	1722	1997	2505	2906	3966	4600	5626	6526	8326	9658	11276	13080	13879	16100
24	600	457	530	1207	1400	2310	2680	3569	4140	5759	6680	8293	9620	11121	12900	15862	18400	18819	21830
28	700	672	780	1853	2150	3362	3900	5440	6310	8608	9985	12069	14000	17250	20010	22586	26200	25862	30000
30	750	724	840	1931	2240	3897	4520	5862	6800	9401	10905	14526	16850	18996	22035	25147	29170	29741	34500
32	800	905	1050	2759	3200	4888	5670	7707	8940	11940	13850	17707	20540	24224	28100	29483	34200	34483	40000
36	900	1103	1280	2948	3420	5905	6850	9914	11500	15500	18000	21552	25000	31034	36000	38578	44750	46720	54195
40	1000	1629	1890	3879	4500	8319	9650	13750	15950	22900	27931	32400	39698	46050	50690	58800	59526	69050	

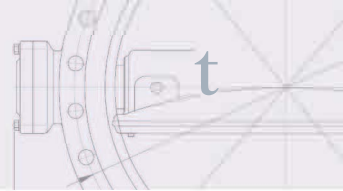

Design Features

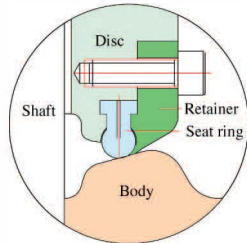

Disc Seat Design

It is designed rubber seat to be inserted in the disc.

More suitable rubber seat can be adopted in accordance with characteristics of fluids.

Rubber seat can be exchanged without dismantling of pipeline.

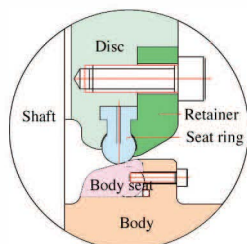

Disc Seat Body Seat Design

It is designed rubber seat to be inserted in the disc.

More suitable rubber seat can be adopted in accordance with characteristics of fluids.

Rubber seat can be exchanged without dismantling of pipeline.

An additional ring is inserted in the body to replace seat ring on the contacting area between body seat and disc seat.

The respective maintenance work is possible for seat and disc seat.

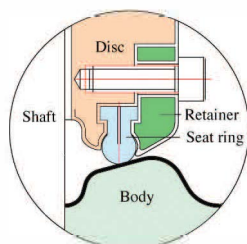

Rubber Lined Design

It is designed rubber seat to be inserted in the disc.

More suitable rubber seat can be adopted in accordance with characteristics of fluids.

Rubber seat can be exchanged without dismantling of pipeline.

No corrosion prevention is available with special coating on the body and disc.

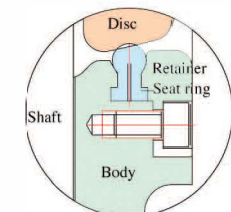

Body Seat Design

It is designed rubber seat to be inserted in the body.

It is more effective design for the disc material of stainless steel.

More suitable rubber seat can be adopted in accordance with characteristics of fluids.

No sealing provision is required on the disc.

Operations

The following actuators of the valves are possible, the choice is depending upon the valve location and the type of work and service for which the valves are used.

- Bare stem type
- Electric motor actuator
- Lever
- Pneumatic actuator
- Gear
- Hydraulic actuator

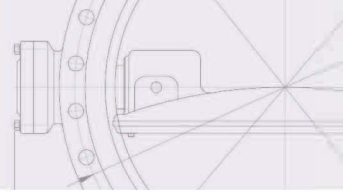

Storage of Valves

- Be careful not to get a scratch on Disc edge and Seat ring.
- The flange must be protected by plywood or other things when carrying valve.
- Valve must not be shocked and shaken too much.
(It may cause the cracking neck, lever, handle and body.)
- It is recommended to be kept and carried under the condition of opening.
- The suitable temperature is from -10°C to 70°C and humidity is between 10%-60% while keeping valve.
- In keeping valve, must check the operation once per months.

Installation Instructions

- Install the valve at the designed place, position and method.
- Prepare sufficient room for valve operation after checking working condition and any obstacles in work place.
- Check if the flow indicating arrow(→) of valve body is conforming to the pipe required direction and check the valve according to the pipe installation specification.
- Detach the protection cover of the valve flange and remove any foreign particles.
- Clearing any dust and deposited outside debris of connection parts of the pipe.
- Prepare more sufficient room when use the new pipeline.
- Don't disassemble any parts of the valve like actuator or gear box. If the disassemble work of the valve parts are needed, please contact with our technical department.
- Preparing enough room for installation,
Leave a space between pipe flange,
Attaching the flange gasket,
Lifting the valve by the center of the valve,
Keeping the valve vertical,
Tightening the flange bolt as vertical and horizontal to flange.
- Tightening the flange bolt regarding the below.
Tightening the bolt with adequate torque to prevent leakage.
- After installation, check the leakage in the connection parts of flange and packing seal at the full open position and then check the same parts at the full close position.
- If there is any leakage at the connection parts, please tighten the flange bolt with adequate torque.
If there is leakage in the packing seal, tighten the gland bolt.
- Should you have any kind of further questions, please kindly contact our company.

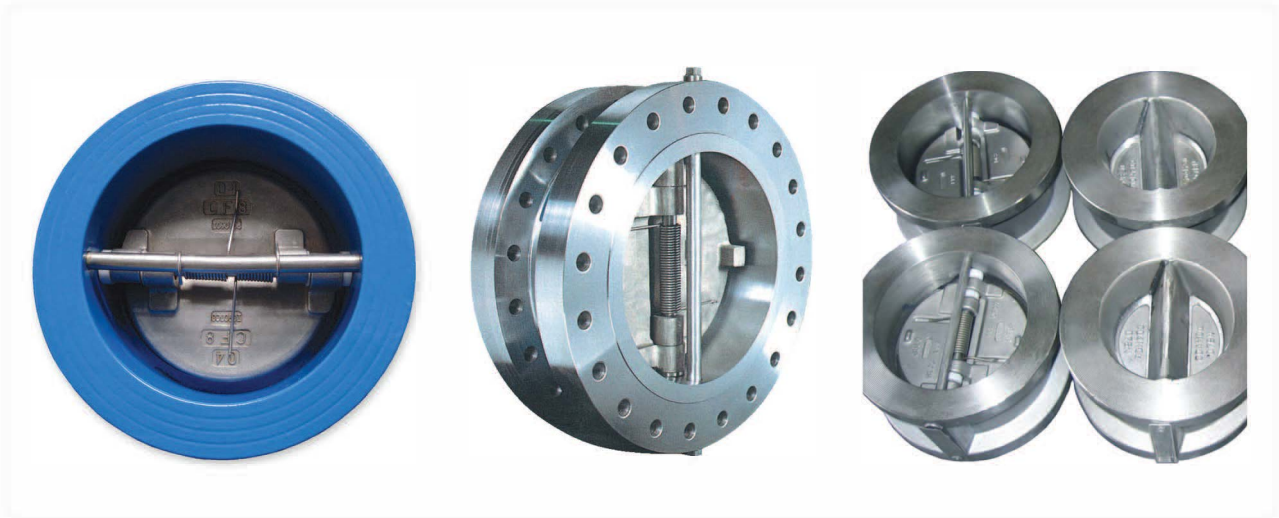

Valve Type

- WAFER - SRS810A Dual Plate Check Valve
- LUG - SRS811A Dual Plate Check Valve
- FLANGE - SRS812A Dual Plate Check Valve

Standard Compliance

- The face to face dimension shall be in accordance with API594, or other STANDARDS are available upon request.

Production Range

- Size : DN 50 to DN 1800 (2 inch - 72 inch)
- Working Pressure : up to 25 bar
- Working Temperature : -20° C - +160° C

Connection Flange

- ANSI B16.1 CL.125LB & B16.5 CL.150LB / MSS SP44 CL.150LB
- AS2129 Table D & E / EN 1092 PN6, PN10 & PN16
- BS10 Table D & E / DIN2501 PN6, PN10 & PN16
- ISO 7005 PN6, PN10 & PN16 / KS / JIS 5K, 10K, 16K & 20K

Face to Face Dimensions

- Conform to API 594

Application

- Chemical, Petrochemical Power generation
- Mechanical engineering Mineral-oil industry
- Textile industry Shipbuilding
- Heating, Air-conditioning, Pipelines
- Wood-working, Pulp and Paper industry
- Iron and Steel industry, Mining industry
- Foodstuff and Allied industries
- Public utilities, Municipal undertakings
- Power Generation
- Mechanical engineering Mineral-oil industry
- Textile industry Shipbuilding

Duo-Check Valve

The short face-to-face design makes dual plate check valves more compact and lighter, providing easy installation and less expensive costs than conventional swing check valves.

This design is standard on all ANSI series 125Ib through 2500Ib valves.

316ss Springs and INCONEL X-750 springs are mostly used with other materials available to meet all service conditions.

The torsion spring is designed to maximize reliability and minimize pressure loss and quickly close the check valve at zero flow to prevent slamming and water hammer commonly associated with many types of other check valves.

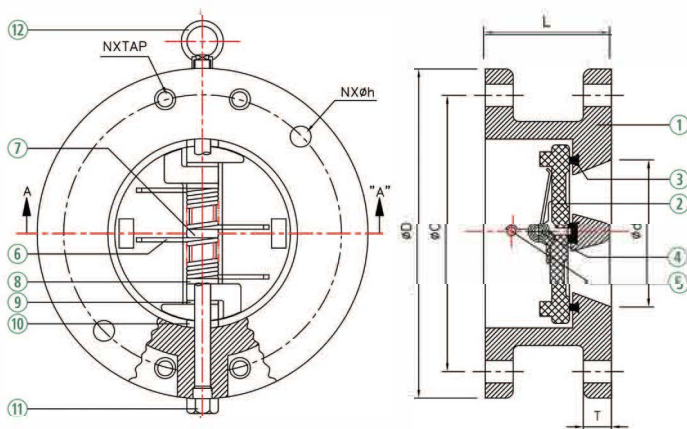

P. No.	PART NAME	MATERIAL
1	BODY	Cast Iron / Ductile Iron / Carbon Steel SS304 / SS316 / Alu-Bronze
2	DISC	Ductile Iron / Carbon Steel / Bronze SS304 / SS316 / Alu-Bronze
3	SEAT	Rubber (NBR / EPDM / SBR / Viton Silicone/ Neoprene) Stainless Steel
4	SPRING	Stainless Steel (SS304 / SS316)
5	HINGE PIN	Stainless Steel (SS304 / SS316)
6	STOP PIN	Stainless Steel (SS304 / SS316)
7	DISC BEARING	Teflon / Stainless Steel
8	PLUGS	Teflon / Stainless Steel
9	EYE BOLT	Steel (DN350 and larger)

Note : Duplex, 254SMO, Monel, Alloy, Inconel, Hastelloy and other special materials are also available and being supplied.

Design Features

- The self acting pivoting check valve of the double disc.
- Maintenance free. The design is compact and space saving.
- The superior closing response prior to flow reveal.
- The corrosion resistant springs are designed to quickly close the valve at zero flow to prevent undesirable pressure surges. In the closed position the valve is tight shut off.
- It opens automatically when the flow starts again.
- The elastomeric seat is vulcanized and bonded to the body casting.
- It is out of the low path thus ensuring extended seal life.
Spherical profiling of the seat ensure positive shut-off even at low pressures and the area adjacent to the seat is also protected by the same elastomeric material.
- Attention paid to the streamlining of the flow path is paramount if good flow characteristics are to be achieved.
- The saving of energy costs by selecting a check valve may be several times the initial cost of the valve.
- The use of these design features together with careful material selection makes a product with high reliability and low operating costs.

SRS 810A - WAFER TYPE Duo-Check Valve

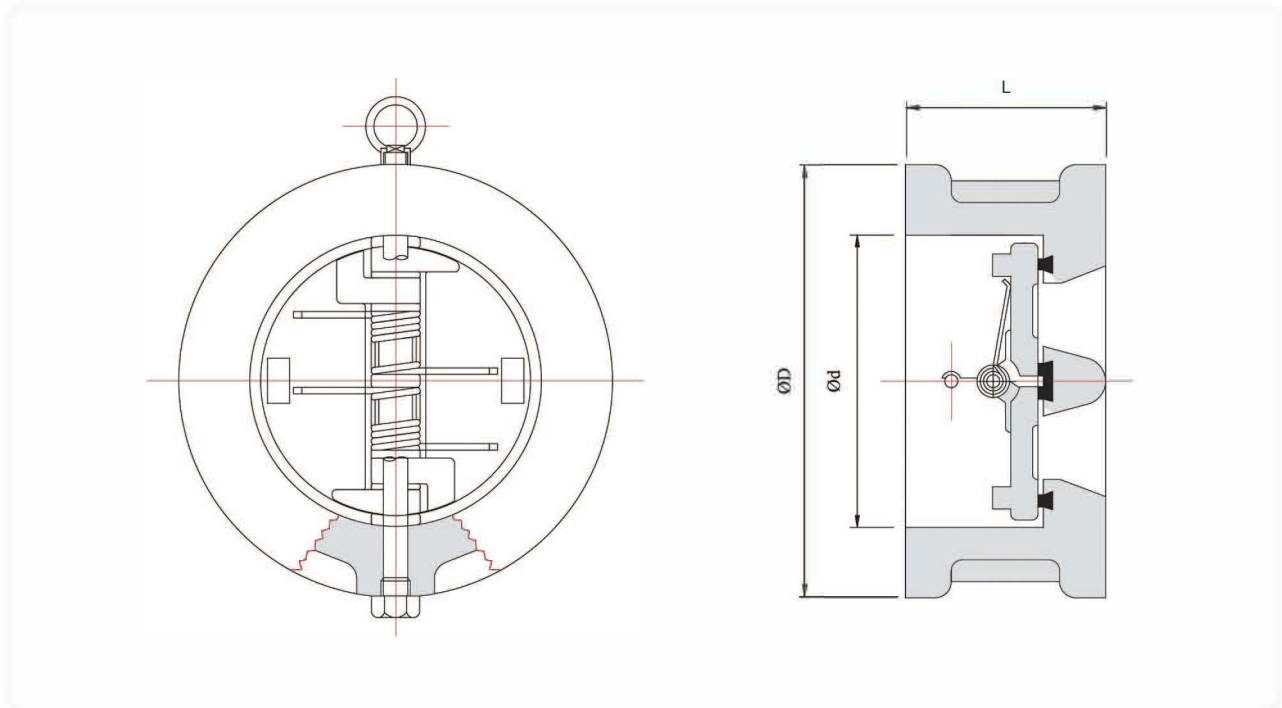

Dimensions

unit: mm

SIZE		Ød		L						ØD						WEIGHT APPROX. (kg) 150LB
inch	mm	mm	in	150LB		300LB		600LB		150LB		300LB		600LB		
		mm	in	mm	in	mm	in	mm	in	mm	in	mm	in	mm	in	
2	50	60	2.4	60	2.4	60	2.4	60	2.4	105	4.1	111	4.4	111	4.4	3.0
2.5	65	73	2.9	67	2.6	67	2.6	67	2.6	124	4.9	130	5.1	130	5.1	4.3
3	80	89	3.5	73	2.9	73	2.9	73	2.9	137	5.4	149	5.9	149	5.9	7.0
4	100	114	4.5	73	2.9	73	2.9	79	3.1	175	6.9	181	7.1	194	7.6	9.0
5	125	141	5.6	86	3.4	86	3.4	105	4.1	197	7.8	216	8.5	241	9.5	12
6	150	168	6.6	98	3.9	98	3.9	136	5.4	222	8.7	251	9.9	267	10.5	18
8	200	219	8.6	127	5.0	127	5.0	165	6.5	279	11.0	308	12.1	321	12.6	32
10	250	273	10.7	146	5.7	146	5.7	213	8.4	340	13.4	362	14.3	400	15.7	53
12	300	324	12.8	181	7.1	181	7.1	229	9.0	410	16.1	422	16.6	457	18.0	98
14	350	356	14	184	7.2	222	8.7	273	10.7	451	17.8	486	19.1	492	19.4	100
16	400	406	16	191	7.5	232	9.1	305	12.0	514	20.2	540	21.3	565	22.2	134
18	450	457	18	203	8.0	264	10.4	362	14.3	549	21.6	597	23.5	613	24.1	144
20	500	508	20	219	8.6	292	11.5	368	14.5	606	23.9	654	25.7	683	26.9	198
24	600	610	24	222	8.7	318	12.5	438	17.2	718	28.3	775	30.5	791	31.1	307
26	650	660	26	222	8.7	318	12.5	438	17.2	773	30.4	835	32.9	867	34.1	350
28	700	711	28	305	12.0	318	12.5	438	17.2	832	32.8	903	35.6	915	36.0	410
30	750	762	30	305	12.0	368	14.5	505	19.9	883	34.8	953	37.5	968	38.1	472
32	800	813	32	356	14.0	368	14.5	505	19.9	940	37.0	1006	39.6	1024	40.3	535
36	900	914	36	368	14.5	483	19.0	635	25.0	1048	41.3	1118	44.0	1130	44.5	683
40	1000	1016	40	419	16.5	483	19.0	635	25.0	1162	45.7	1115	43.9	1155	45.5	1247
42	1050	1067	42	432	17.0	568	22.4	701	27.6	1219	48.0	1166	45.9	1220	48.0	1271
48	1200	1219	48	524	20.3	629	24.8	701	27.6	1384	54.5	1274	50.2	1392	54.8	1996
54	1350	1372	54	540	21.3	629	24.8	701	27.6	1549	61.0	1493	58.8	1556	61.3	2895
60	1500	1524	60	660	26.0	650	25.6	750	29.5	1715	67.5	1645	64.8	1735	68.3	3645
72	1800	1829	72	914	36.0	650	25.6	750	29.5	2051	80.7	-	-	-	-	6375

* Specification and design are subject to change without notice

SRS 812A - FLANGE TYPE Duo-Check Valve

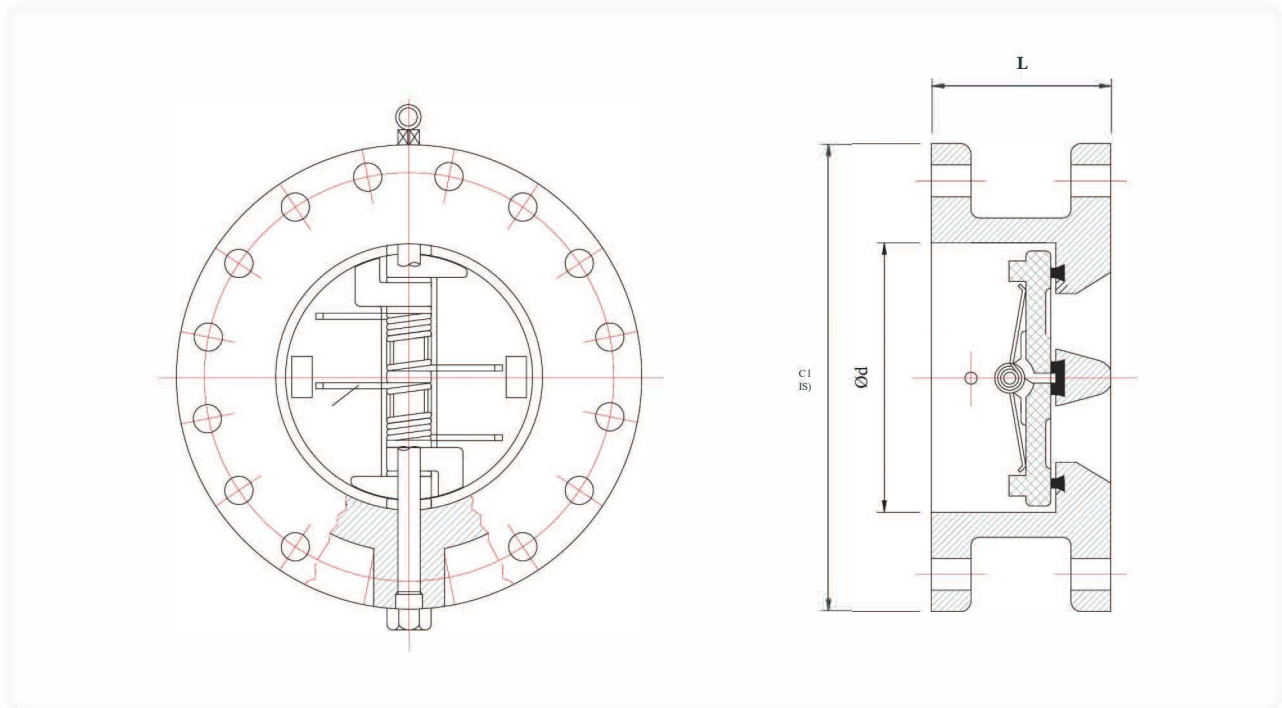

Dimensions

unit: mm

SIZE		Ød		L						ØD						WEIGHT APPROX. kg 150LB	
				150LB		300LB		600LB		150LB		300LB		600LB			
inch	mm	mm	in	mm	in	mm	in	mm	in	mm	in	mm	in	mm	in	mm	in
2	50	60	2.4	60	2.4	60	2.4	60	2.4	165	6.5	165	6.5	165	6.5	4.0	
2.5	65	73	2.9	67	2.6	67	2.6	67	2.6	191	7.5	191	7.5	191	7.5	7.4	
3	80	89	3.5	73	2.9	73	2.9	73	2.9	210	8.3	210	8.3	210	8.3	8.4	
4	100	114	4.5	73	2.9	73	2.9	79	3.1	229	9.0	254	10	273	10.7	13.5	
5	125	141	5.6	86	3.4	86	3.4	105	4.1	254	10.0	279	11	330	13.0	16	
6	150	168	6.6	98	3.9	98	3.9	136	5.4	279	11.0	318	12.5	356	14.0	22	
8	200	219	8.6	127	5.0	127	5.0	165	6.5	343	13.5	381	15	419	16.5	44	
10	250	273	10.7	146	5.7	146	5.7	213	8.4	406	16.0	445	17.5	508	20.0	86	
12	300	324	12.8	181	7.1	181	7.1	229	9.0	483	19.0	521	20.5	559	22.0	100	
14	350	356	14.0	184	7.2	222	8.7	273	10.7	533	21.0	584	23	603	23.7	127	
16	400	406	16.0	191	7.5	232	9.1	305	12.0	597	23.5	648	25.5	686	27.0	162	
18	450	457	18.0	203	8.0	264	10.4	362	14.3	635	25.0	711	28	743	29.3	190	
20	500	508	20.0	219	8.6	292	11.5	368	14.5	699	27.5	775	30.5	813	32.0	254	
24	600	610	24.0	222	8.7	318	12.5	438	17.2	813	32.0	914	36	940	37.0	403	
26	650	660	26.0	222	8.7	318	12.5	438	17.2	870	34.3	972	38.3	1016	40.0	483	
28	700	711	28.0	305	12.0	318	12.5	438	17.2	927	36.5	1035	40.7	1073	42.2	543	
30	750	762	30.0	305	12.0	368	14.5	505	19.9	984	38.7	1092	43	1130	44.5	696	
32	800	813	32.0	356	14.0	368	14.5	505	19.9	1060	41.7	1149	45.2	1194	47.0	855	
36	900	914	36.0	368	14.5	483	19.0	635	25.0	1168	46.0	1270	50	1314	51.7	1220	
40	1000	1016	40.0	419	16.5	483	19.0	635	25.0	1289	50.7	1238	48.7	1320	52.0	1410	
42	1050	1067	42.0	432	17.0	568	22.4	701	27.6	1346	53.0	1289	50.7	1403	55.2	1560	
48	1200	1219	48.0	524	20.3	629	24.8	701	27.6	1511	59.5	1416	55.7	1500	59.5	1770	
54	1350	1372	54.0	540	21.3	629	24.8	701	27.6	1683	66.3	1657	65.2	1778	70.0	1865	
60	1500	1524	60.0	660	26.0	650	25.6	750	29.5	1854	73.0	1810	71.3	1994	78.5	2110	
72	1800	1829	72.0	914	36.0	650	25.6	750	29.5	2197	86.5	-	-	-	-	2435	

* Specification and design are subject to change without notice

Engineering Data

Cv-value Capacity, ANSI 150#/300#		Min. Flow Velocity & Pressure Drops@ V(min)		
Valve Size	Cv	Min. Flow Velocity V(min), M/sec	Max. Pressure Drops at V(min), bar	
2"	DN50	48	1.2	0.28
2.5"	DN65	86	1.2	0.28
3"	DN80	128	1.2	0.25
4"	DN100	278	1.2	0.2
5"	DN120	430	0.9	0.2
6"	DN150	680	0.9	0.18
8"	DN200	1370	0.9	0.12
10"	DN250	2360	0.8	0.1
12"	DN300	3760	0.8	0.1
14"	DN350	5080	0.8	0.1
16"	DN400	7430	0.8	0.08
18"	DN450	10100	0.6	0.08
20"	DN500	12900	0.6	0.08
24"	DN600	24100	0.6	0.08

The Minimum Flow Velocity, V (min) to be opened in full flow condition (when the discs are to be stable position) is calculated as following equation.

$$V(\text{min}) = 60 \sqrt{\frac{8(KT+Wd)}{\pi L D^2 \times 10^{-6}}} \text{ m/sec}$$

Where,

KT = Applicable Spring Torsional Coefficiency, Kgf/mm,

Wd = Disc Weight, kgf

L = Spring Arm Rest total length, mm

D = Nominal Valve Size, DN(mm)

Installation

The Check valve is designed for steady flow condition and can be installed in horizontal and vertical pipelined but the instructions shown must be adhered to.

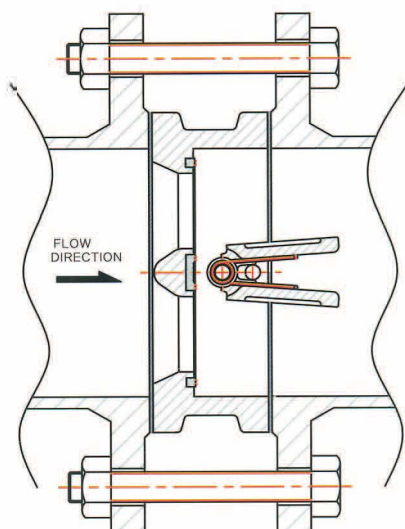

* The disc shaft must be in the vertical position

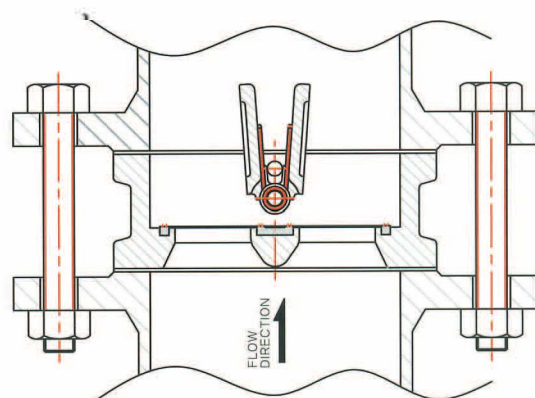

* As standard the valve must be installed with flow up.

The valve must not be installed in pipelines with pulsating flow or near to reciprocating pumps. Additional pressure drop can be expected due to the weight of the discs

anc corporation

www.ancvalve.co.kr

Head Office

116-219, Busan T-PLEX, 41, Yutongdanji 1-ro, Gangseo-gu, Busan, Korea
Tel. +82 51 796 1570 / Fax. +82 51 796 1571 / ancvalve@daum.net

France Office (Giangrasso)

11 Avenue des Acacias 06500 Menton France
Tel. +33 4 93 28 36 06 / Fax. +33 4 92 10 15 35 / marc.giangrasso@orange.com